



# Multi-Parameter Water Quality Meter **LB-11PMT**

**Operational Manual**

## Index

<b>Sr. No</b>	<b>Title</b>	<b>Page no</b>
1.	Introduction	2
2.	Features	2
3.	Specifications	3
4.	Applications	4
5.	Instrument Introduction	5
6.	Installation	9
7.	Operations	11
8.	Troubleshooting	66
9.	Accessories	67

## 1. Introduction

**Multi-Parameter Water Quality Meter LB-11PMT** measures pH from - 2.000 to 20.000 pH with an accuracy of  $\pm 0.002$  pH. It also measures ORP, conductivity, dissolved oxygen, salinity, and temperature for a complete water quality assessment. It utilizes high-quality titanium alloy probes that ensure accurate measurements. Our meter features a high-quality LCD for user-friendly operation and easy data monitoring.

## 2. Features

- ATC for precise temperature readings
- Auto shut-off to save battery
- Automatic data saving
- Salinity and pressure compensation
- Automatic buffer recognition

## 3. Specifications

<b>Model No</b>	<b>LB-11PMT</b>
<b>pH Range</b>	- 2.000 to 20.000 pH
<b>pH Resolution</b>	0.001, 0.01, 0.1 pH, selectable
<b>pH Accuracy</b>	± 0.002 pH
<b>pH Calibration Points</b>	1 to 5 points
<b>ORP Range</b>	± 1999.9 mV
<b>ORP Resolution</b>	0.1, 1 mV, selectable
<b>ORP Accuracy</b>	± 0.2 mV
<b>ORP Calibration Points</b>	1 point
<b>Ion Measurement Range</b>	0.001 to 19999 (depending on ISE)
<b>Ion Measurement Resolution</b>	0.001, 0.01, 0.1, 1
<b>Ion Measurement Accuracy</b>	± 0.5% F.S. (monovalent), ±1% F.S. (divalent)
<b>Ion Calibration Points</b>	2 to 5 points (0.001, 0.01, 0.1, 1, 10, 100, 1000, 10000)
<b>Conductivity Range</b>	0.01 to 20.00, 200.0, 2000 µS/cm, 20.00, 200.0 mS/cm
<b>Conductivity Resolution</b>	0001,0.01,0.1,1
<b>Conductivity Accuracy</b>	± 0.5% F.S.
<b>TDS Range</b>	0 to 10.00, 100.0, 1000 ppm, 10.00, 200.0 ppt
<b>TDS Resolution</b>	001,0.1,1
<b>TDS Accuracy</b>	± 1% F.S.
<b>Salinity Range</b>	0.00 to 42.00 psu, 0.00 to 80.00 ppt
<b>Salinity Resolution</b>	0.01
<b>Salinity Accuracy</b>	± 1% F.S.
<b>Resistivity Range</b>	0.00 to 20.00 MΩ
<b>Resistivity Accuracy</b>	± 1% F.S.
<b>DO Range</b>	0.00 to 20.00 mg/L, 0.0 to 200.0% saturation
<b>DO Resolution</b>	001mg/L,0.1%
<b>DO Accuracy</b>	± 0.2 mg/L, ± 2.0%
<b>Temperature Compensation</b>	0 to 100°C/32 to 212°F, manual or automatic
<b>Memory Capacity</b>	500 data sets
<b>Power</b>	3 × 1.5V AA batteries or DC5V power adapter

## Multi-Parameter Water Quality Meter LB-11PMT

<b>Dimensions (W × D × H)</b>	170 × 85 × 30 mm
<b>Shipping Size (W × D × H)</b>	450 × 320 × 100 mm
<b>Net Weight</b>	0.3 kg
<b>Gross Weight</b>	2 kg

### 4. Applications

Multi-Parameter Water Quality Meter LB-11PMT is used for monitoring water quality in various areas, including aquariums, hydroponics, marine environments, and aquaculture.

## 5. Instrument Introduction

### 5.1 Meter Overview

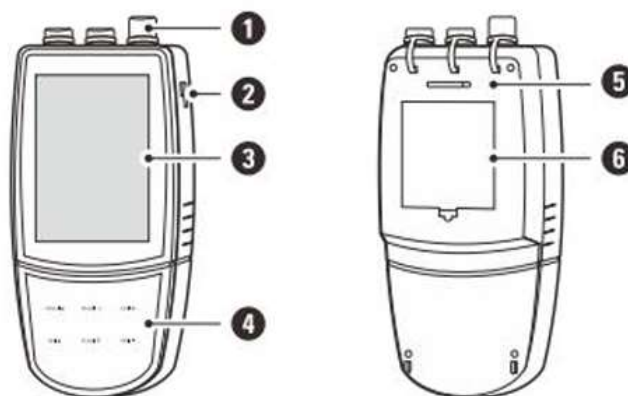

**Figure-1**

- 1) Sensor Connections
- 2) Slot for electrode clip
- 3) Display
- 4) Membrane keyboard
- 5) Slot for hand strap
- 6) Battery Compartment

### 5.2 Connectors

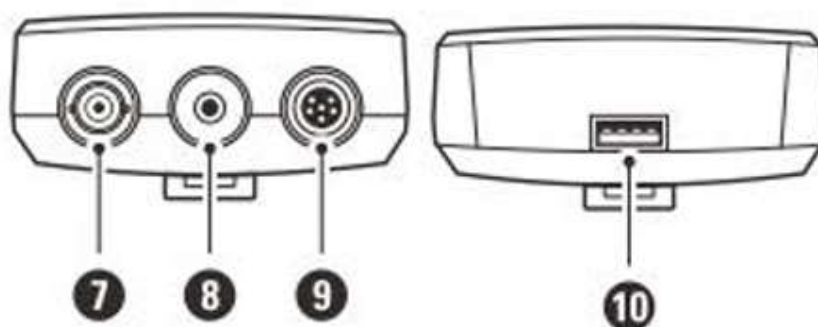

**Figure-2**

- 7) Socket for pH, ORP or ion selective electrode (BNC)
- 8) Socket for temperature probe (3.5 mm jack)
- 9) Socket for conductivity or dissolved oxygen electrode (6-pinDIN)
- 10) USB-A interface to the computer or power adapter



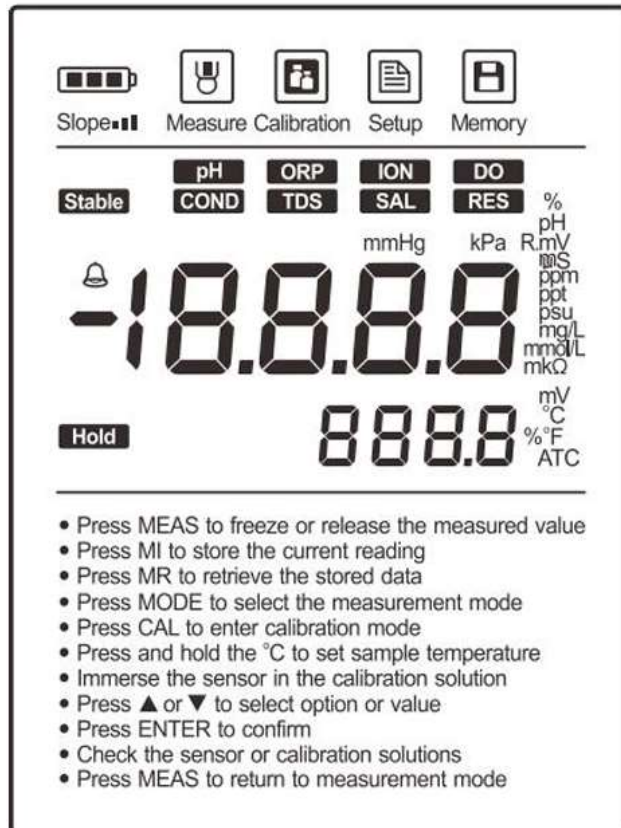









## 5.3 Display



**Figure-3**

Icon	Description
	Indicates that the meter is in the measurement mode
	Indicates that the meter is in the calibration mode
	Indicates that the meter is in the setup mode
	Indicates that you are viewing the stored readings or a reading is stored into the memory
	Low Battery Alarm - When the battery voltage falls below the minimum power requirements, the icon automatically disappears

## Multi-Parameter Water Quality Meter LB-11PMT





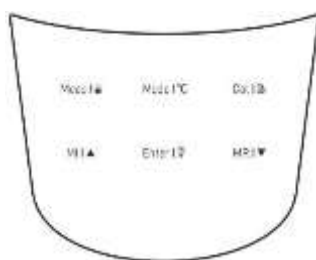

Slope 	Electrode Condition Indicator - If the pH electrode slope exceeds the allowed range after calibration, the icon automatically disappears
	Calibration Due Alarm - If the electrode has not been re-calibrated within a specified time, the icon automatically shows
ATC	Indicates that automatic temperature compensation is enabled
	Shown when the measurement is stable
	Shown when the reading is locked
	pH mode
	Oxidation reduction potential (ORP) mode
	Ion concentration mode
	Conductivity mode
	Total dissolved solids (TDS) mode
	Salinity mode
	Resistivity mode
	Dissolved oxygen mode

### 5.4 Keypad



**Figure-3**

## Multi-Parameter Water Quality Meter LB-11PMT

Key	Function
	Switch the meter on or off Lock or unlock the measurement Exit the calibration, settings, data logs and return to the measurement mode
	Select the measurement mode Press and hold the key to enter the temperature setting
	Start calibration Press and hold the key to enter the setup menu
	Store current reading to memory Increase value or scroll up through a list of options
	View the data logs or calibration logs Decrease value or scroll down through a list of options
	Confirm the calibration or displayed option Press and hold the key to switch the backlight on or off

## 6. Installation

### 6.1 Environment Conditions

Before unpacking, ensure that the current environmental conditions comply with the following requirements:

- Relative humidity is below 80%
- Ambient temperature is between 0°C (32°F) and 50°C (122°F)
- The area is free from electromagnetic interference
- No presence of corrosive gases in the environment

### 6.2 Installing the batteries

- 1) Open the battery compartment by removing the cover on the back of the meter.

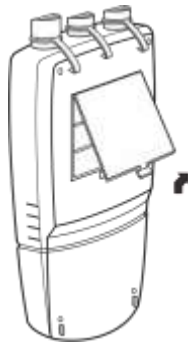

**Figure- 4**

- 2) Insert three AA alkaline batteries into the battery compartment, ensuring correct polarity.

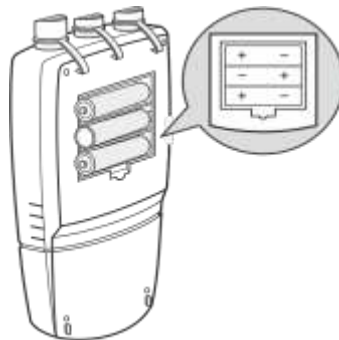

**Figure-5**

- 3) Replace the battery compartment cover and press the limiter until it clicks into place.



**Figure-6**

## 6.3 Using the power adapter

The meter allows the use of the DC 5V power adapter or the USB port on computer as a power supply.



**Figure-7**

**Note:** Remove the batteries before connecting an external power supply.

## 6.4 Installing the Electrode Clip

The electrode clip is an optional accessory used for mounting a sensor and is not essential for the operation of the meter. To install it, insert the clip into the slot located on the right side of the meter.



**Figure-8**

## 7. Operations

### 7.1 Switching the Meter on and Off

- Press and release the Meas key to turn on the meter.
- Press and hold the Meas key to turn off the meter.



Figure-9

### 7.2 Temperature Calibration

The meter includes a TP-10K temperature probe for measurement and temperature compensation. If the temperature reading differs from that of a reliable thermometer, the probe should be calibrated.

**Note:** The dissolved oxygen electrode features a built-in temperature sensor, so the external probe is not required when using that electrode.

To calibrate the temperature probe:

- 1) Connect the temperature probe to the meter and place it in a solution with a known, accurate temperature.
- 2) Press and hold the °C key to enter temperature calibration mode.
- 3) Use the ▲ / ▼ keys to adjust the temperature value.
- 4) Press the Enter key to confirm and save the setting.

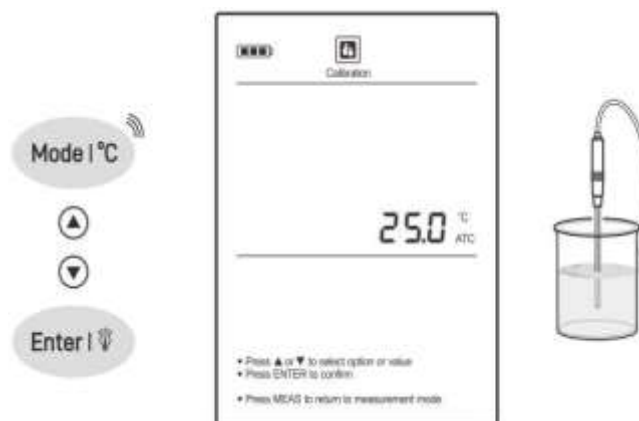

Figure-10

## 7.3 General Setting

The meter features an integrated setup menu that allows customization of functional parameters. Depending on the selected mode, the display will show the relevant menu options. General settings apply universally across all modes once they are configured.

Menu Item	Option and Description
<b>Stability Criteria</b> Set when a measurement is recognized as stable.	
StR	
LO	Standard (default)
HI	High accuracy
<b>Auto-Hold</b> If enabled, the meter will automatically sense and lock the measurement endpoint.	
HOLD	
YES	Enable
NO	Disable (default)
<b>Auto-Power Off</b> If enabled, the meter will automatically switch off if no key is pressed within a specified time period.	
OFF	
...30	10, 20, 30 minutes
NO	Disable (default)

## 7.4 Setting a default Option

- 1) In measurement mode, press and hold the key to access the setup menu.
- 2) Use the ▲ key to navigate and select a menu item.

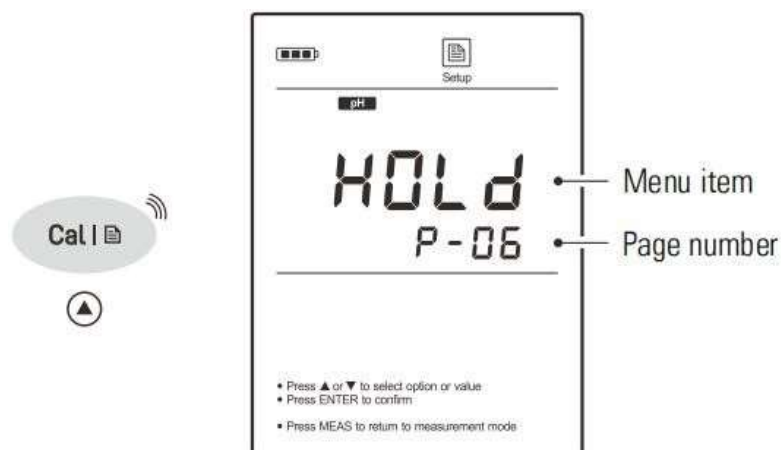

**Figure-11**

- 3) Press the **Enter** key to display the current setting for the selected option.

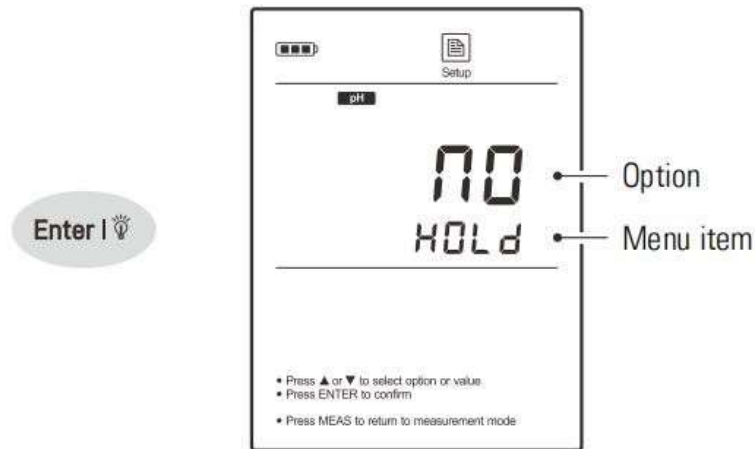

**Figure-12**

- 4) Use the ▲ / ▼ keys to choose the desired option, then press the **Enter** key to confirm and save the setting.

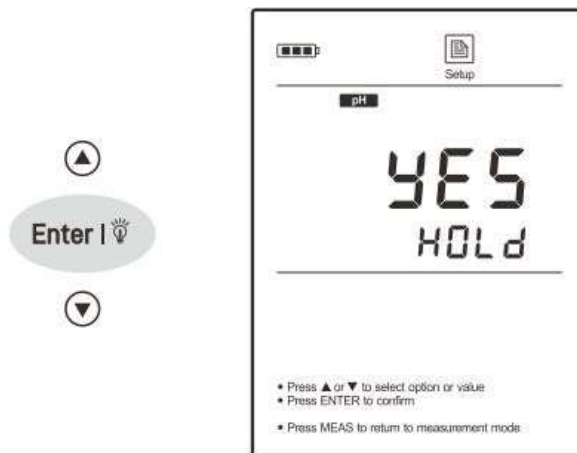

**Figure-13**

To exit the setup menu without saving changes, press the Meas key.

## 7.5 Setting the Date and Time

- 1) While in measurement mode, press and hold the key to access the setup menu.
- 2) Press the ▼ key repeatedly until the meter displays the Date option.



**Figure-14**

3) Press the **Enter** key, the meter shows the current year.



**Figure-15**

4) Use the ▲ / ▼ keys to adjust the year, then press the **Enter** key to proceed to the date and time settings.



**Figure-16**

- 5) Use the ▲ / ▼ keys to set the month, day, hour, and minute. Press the Enter key after each adjustment to save the settings. Continue until the meter returns to measurement mode.

## 7.6 pH Calibration and Measurement

### 7.6.1 Prior Use

#### 1) Preparation of pH Buffer Solutions

The meter comes with pH 4.01, 7.00, and 10.01 buffer reagents needed for calibration.

- 1) Fill a 250 mL volumetric flask halfway with distilled water and add the pH 7.00 buffer reagent.
- 2) Gently swirl the flask to dissolve the reagent, then fill to the calibration mark with distilled water.
- 3) Cap the flask and invert it several times to ensure the solution is thoroughly mixed.

Prepare the pH 4.01 and 10.01 buffer solutions using the same procedure. Store all prepared buffer solutions in tightly sealed glass containers and keep them away from direct sunlight.

#### 2) Connecting the Electrode

- 1) Remove the pH electrode from the carrying case. Connect the BNC connector to the meter by inserting it into the socket, then rotate and push it clockwise until it locks securely in place.



Figure-17

- 2) Take off the protective cap from the bottom of the electrode. If small air bubbles are visible inside the pH-sensitive glass membrane, gently shake the electrode downward to eliminate them.

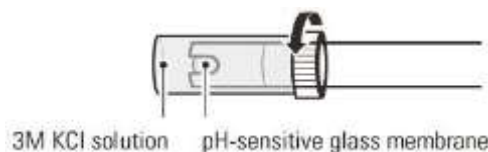

Figure-18

## 7.6.2 Selecting the measurement mode

Press the Mode key until the pH icon appears on the display. The meter will then enter pH measurement mode.

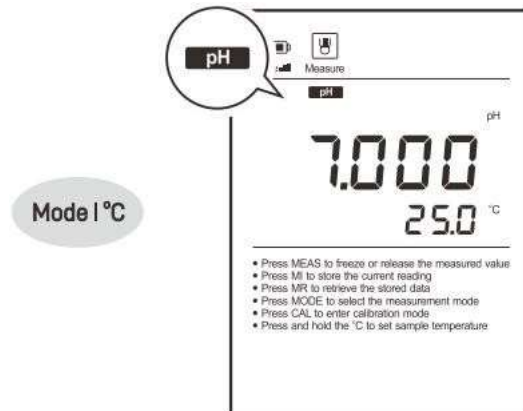

Figure-19

## 7.6.3 pH Setting

The meter contains 4 pH settings and 7 general settings in the setup menu.

	<b>pH Buffer Group</b> Set the pH buffer group for calibration and auto-recognition.	
BUF	USA	USA (default)
	NIST	NIST
	DIN	DIN
	USE r	Custom buffers (any 2 values >1 pH apart)
	<b>Calibration Points</b> Set the number of calibration points.	
CAL	3	1 to 5 points (default 3 points)
	<b>Resolution</b> Set the resolution of the pH measurement.	
RESO	0.001	0.001 (default)
	0.01	0.01
	0.1	0.1
	<b>Measurement Unit</b> Set the default temperature unit.	
UNIT	°C	Degrees Celsius (default)
	°F	Degrees Fahrenheit

To modify the current settings, press and hold the key to access the setup menu. Use the ▲ / ▼ keys to navigate through the options and press the Enter key to confirm your selection.

## 7.6.4 Temperature compensation

For improved accuracy, it is recommended to use a sensor with a built-in temperature sensor or a separate temperature probe. The meter will use the measured temperature to calculate the pH slope and display temperature-compensated readings.

### 1) Automatic Temperature Compensation

Connect the temperature probe to the meter. The ATC icon will appear on the display, indicating that the meter has switched to automatic temperature compensation mode.



Figure-20

### 2) Manual Temperature Compensation

If the meter does not detect a temperature probe, the °C (degrees Celsius) icon will appear on the display, indicating that the meter has switched to manual temperature compensation mode. To set the temperature manually, follow these steps:

- 1) Press and hold the °C key to enter temperature setting mode.
- 2) Use the ▲ or ▼ keys to adjust the temperature value.
- 3) Press the Enter key to save your setting.

**Tip:** Pressing and holding the ▲ or ▼ key will change the temperature value more quickly.

## 7.6.5 pH Calibration

- The meter supports pH calibration with anywhere from 1 to 5 points. For optimal accuracy, it is recommended to perform at least a 2-point calibration.
- It automatically detects and calibrates to recognized standard buffer values.

USA Standard Buffers	pH 1.68, 4.01, 7.00, 10.01, 12.45
NIST Standard Buffers	pH 1.68, 4.01, 6.86, 9.18, 12.45
DIN Standard Buffers	pH 1.09, 4.65, 6.79, 9.23, 12.75

Figure-21

- If the **USER** option is selected, the meter will only allow 2 points calibration. Single point calibration should only be carried out with pH 7.00, 6.86 or 6.79, otherwise calibration will not be accepted.
- Calibration is essential when a new pH electrode is installed or when the meter is being used for the first time.
- Avoid reusing buffer solutions after calibration, as contamination can lead to inaccurate calibration and unreliable measurements.
- For improved accuracy, it is best to enable automatic temperature compensation. If manual compensation is used instead, ensure that both the buffer and sample solutions are at the same temperature, and that the correct temperature is entered into the meter.
- Maintain a consistent stirring speed for both standards and samples to help achieve the most accurate results possible.

### Single Point Calibration

- 1) Make sure that 1-point calibration is selected in the setup menu.
- 2) Press the Cal key. The meter will display 7.00/CAL, 6.86/CAL, or 6.79/CAL, based on the chosen pH buffer group.

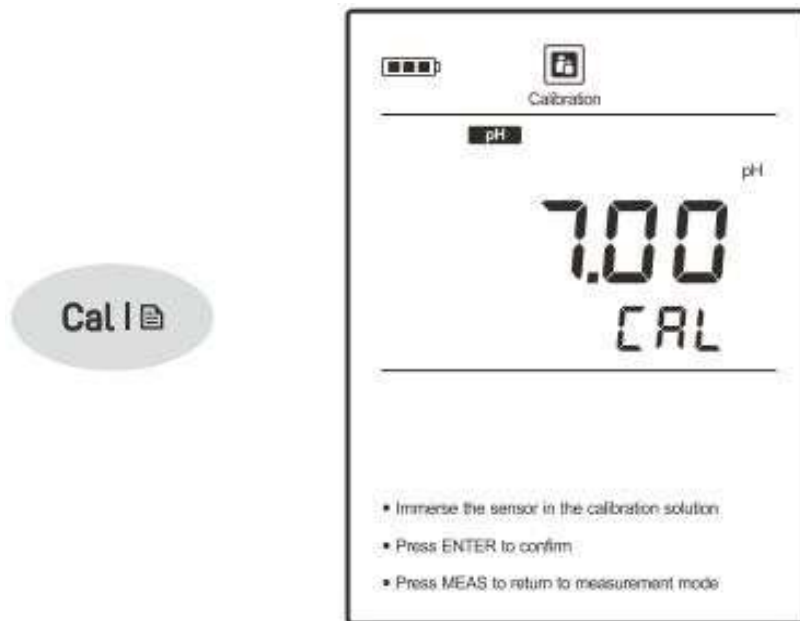

Figure-22

- 3) Rinse the pH electrode with distilled water, then immerse both the electrode and the temperature probe into the pH 7.00 buffer solution. Stir gently to ensure the solution is well mixed and uniform.
- 4) Press the **Enter** key, the Calibration icon begins flashing.

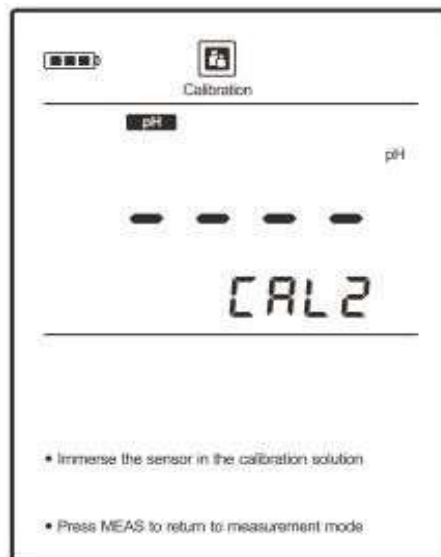

**Figure-23**

- 5) When the reading has stabilized, the meter will show *End* and return to the measurement mode.

### **Multipoint Calibration**

- 1) Confirm that the calibration mode is set to 2 to 5 points in the setup menu.
- 2) Follow the procedure outlined in steps 1 through 4. After the first calibration point is successfully completed, the display will read ----/CAL2, indicating that the meter is ready for the second point of calibration.



**Figure-24**

- 3) Rinse the pH electrode with distilled water, place the electrode (and temperature probe) into the next buffer solution (e.g., pH 4.01).

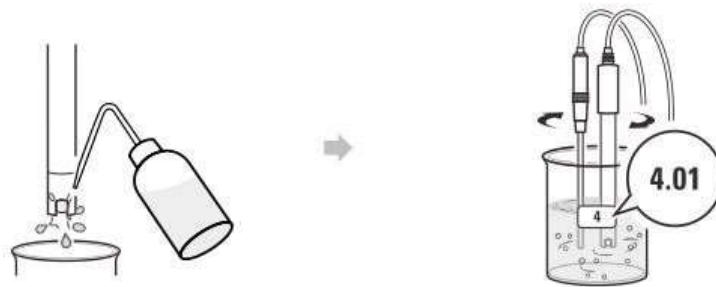

**Figure-25**

The meter will automatically detect the buffer solution and initiate calibration, with the Calibration icon flashing continuously during the process.



**Figure-26**

- 4) Once the reading stabilizes, the display will indicate ---/CAL3, signaling that the meter is ready for the third calibration point.
- 5) Repeat step 3 for each additional calibration point until the meter indicates that calibration is complete.



Figure-27

## pH Calibration with Custom Buffers

- 1) Ensure that you have selected the *USER* option in the setup menu, the custom buffer solutions should be at least 1 pH unit apart from each other.

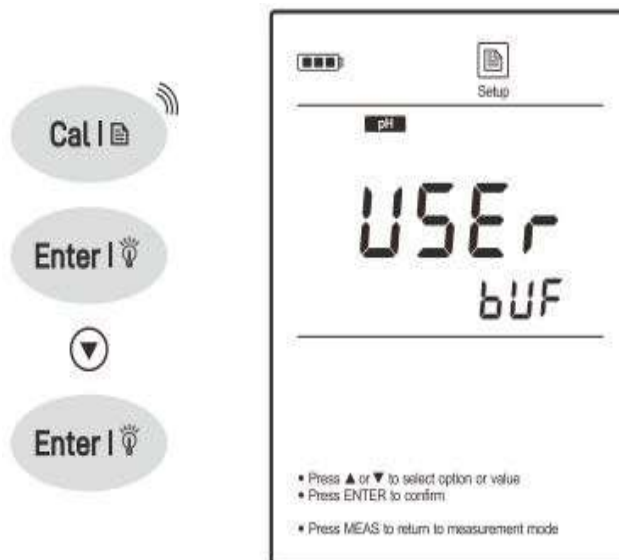

Figure-28

- 2) Rinse the pH electrode with distilled water, then immerse both the electrode and the temperature probe into the buffer solution. Stir the solution gently and wait for the reading to stabilize.
- 3) Press the **Cal** key to enter calibration mode.



**Figure-29**

- 4) If necessary, press the ▲ / ▼ key to set the calibration value, press the Enter key to begin the calibration.

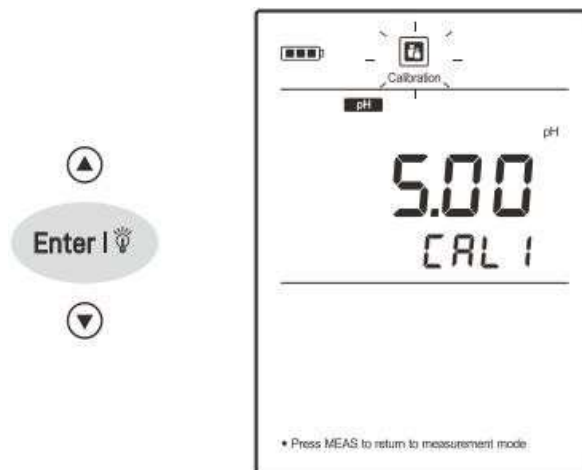

**Figure-30**

- 5) When the reading has stabilized, the display will show CAL2. The meter prompts you to continue with second point calibration.

- 6) Repeat the steps 2 and 4 above until the meter shows **End**. Calibration is completed.
- During the calibration, if the display shows indicating the meter is waiting for recognizing the pH buffer solution.
  - If the display shows **Err** indicating the measured mV value for the current calibration point deviates by more than 60 mV from the theoretical value of the pH buffer. The calibration will not be accepted. Kindly check the pH electrode and buffer solutions.
  - If the calculated electrode slope is not between 70% to 110%, **Slope** icon will disappear from the display. The pH electrode may need to be replaced.
  - To exit the calibration without saving changes, press the **Meas** key.

## 7.6.6 Viewing the calibration log

- 1) Press the **MR** key in the pH measurement mode and press the **▼** key until the meter shows **ELE/P-02** (Electrode).
- 2) Press the **Enter** key, the meter shows the last calibration date.

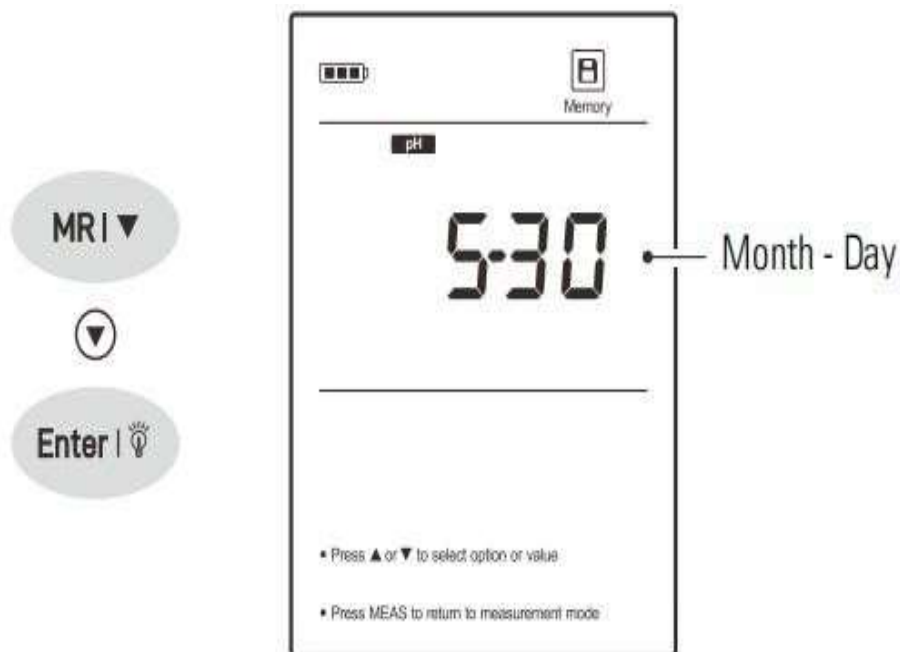

**Figure-31**

- 3) Press the **▼** key to view the zero-point offset.

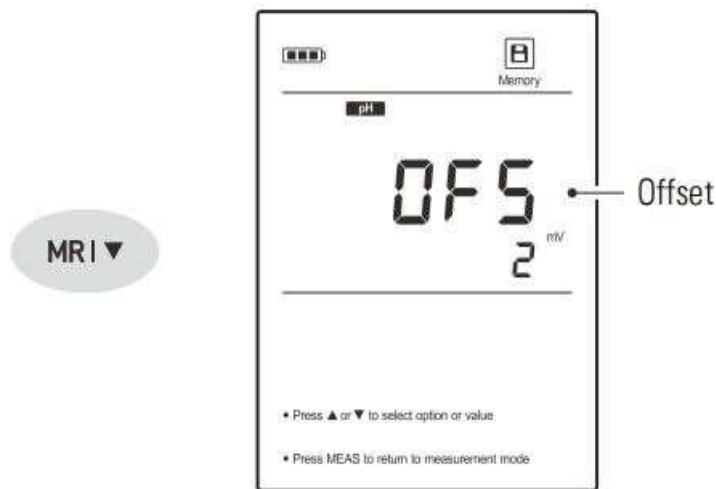

**Figure-32**

- 4) Press the ▼ key to view the calibration points and electrode slope.

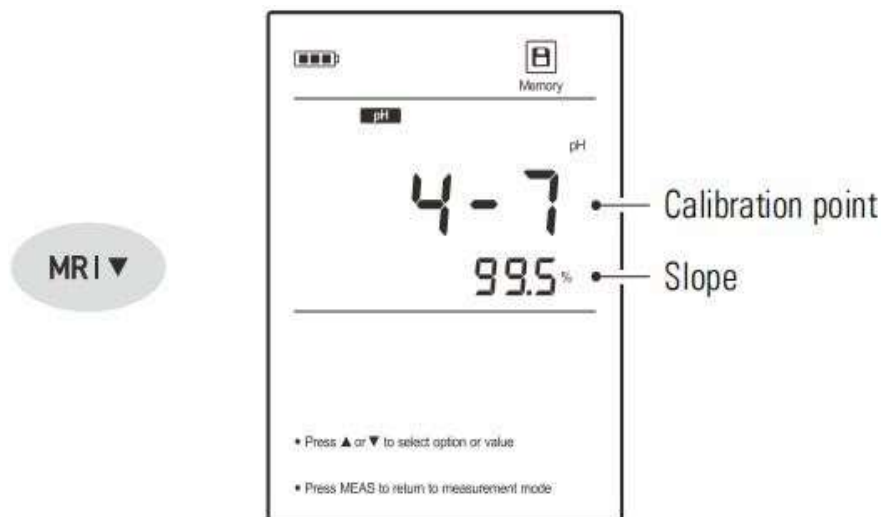
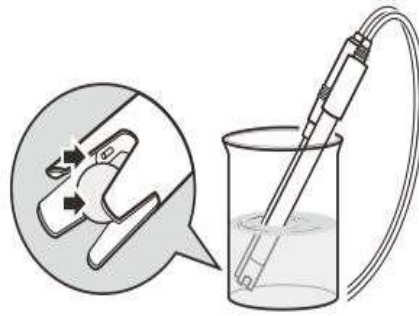

**Figure-33**

- 5) To exit the calibration log, press the **Meas** key.  
If the meter is not calibrated or custom buffers are used, the display will show -only.

### 7.6.7 pH Measurement

- 1) Rinse the pH electrode with distilled water. Place the electrode (and temperature probe) into the sample solution and stir gently. **Note**, the pH-sensitive glass membrane and liquid junction must be completely immersed into the solution.



**Figure-34**

- 2) If the Auto-Hold option in the setup menu is enabled, the meter will automatically sense a stable reading and lock measurement, the **HOLD** icon appears on the display. Press the  key to resume measuring.
- 3) If the option is disabled, the meter will continuously measure and update the readings.

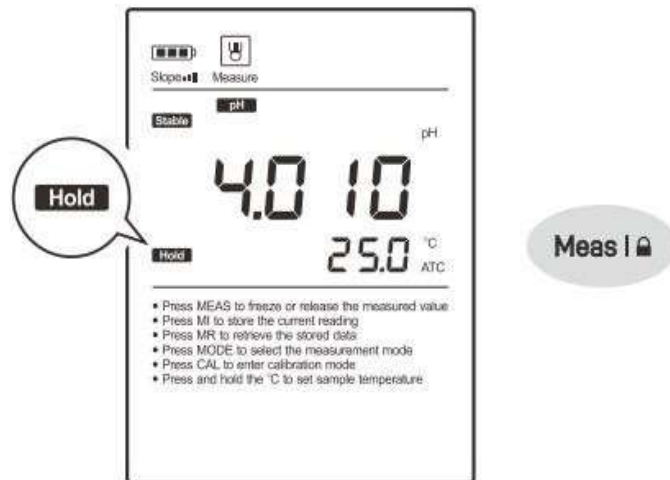

**Figure-35**

- 4) Wait for the measurement to stabilize and record the reading.
- 5) When all the samples have been measured, rinse the electrode according to the instructions in the Electrode Maintenance.
  - During the measurement process, never wipe the pH-sensitive glass membrane as this will cause static interference, blot dry with a lint-free tissue to remove water drops on electrode.
  - If the meter shows indicating the measurement exceeds the range, remove the electrode from the sample immediately.
  - If your sample is pure water, low ionic or low conductivity water, we recommend measuring the pH in the smallest sample volume possible or adding 0.3 ml of the 3M KCl to 100 ml of the sample solution. Note, only high purity KCl can be used.
  - To record the measurement at the predefined time intervals, refer to the Interval Readings section.

## 7.6.8 Electrode Maintenance

### 1) Cleaning the pH Electrode

Since pH electrode is susceptible to contamination, thoroughly clean as necessary after each use.

#### General Cleaning

Rinse the pH electrode with distilled water and soak in 3M KCl solution.

#### Salt Deposits

Dissolve the deposit by immersing the electrode in warm tap water. Rinse the electrode with distilled water and soak in 3M KCl solution.

#### Oil or Grease

Place the electrode in the detergent or ethanol solution for 15 minutes. Rinse the electrode with distilled water and soak in 3M KCl solution.

#### Protein

- Add 1% pepsin to 0.1M HCl solution.
- Place the electrode in above solution for 15 minutes.
- Rinse the electrode with distilled water and soak in 3M KCl solution.

#### Clogged Liquid Junction

- Heat a diluted KCl solution to 60°C (140°F).
- Place the electrode into the heated solution for 10 minutes.
- Allow the electrode to cool in unheated KCl solution.

### 2) Reactivating the pH Electrode

If the pH-sensitive membrane has dried out, the electrode response will become sluggish. Immerse the electrode in a pH 4.01 buffer solution for about 30 minutes to rehydrate. If this fails, the electrode requires activation.

- 1) Soak the electrode in a 0.1M of HCl for 10 minutes.
- 2) Remove and rinse with distilled water, then place into a 0.1M of NaOH for 10 minutes.
- 3) Remove and rinse again and soak in 3M KCl solution for at least 6 hours. If these steps fail to restore the response, replace the electrode.  
If these steps fail to restore the response, replace the electrode.

### 3) Storing the pH Electrode

- 1) For best results, always soak the electrode in 3M KCl solution.
- 2) If above solution is not available, use a pH 4.01 buffer solution.



Do not store the electrode in distilled or deionized water that will deplete the hydration layer of the pH-sensitive membrane and render the electrode useless.

- 3) If you do not use the electrode for a period longer than 1 month, store the electrode in storage solution.

### 4) Preparation of Electrode Storage Solution

- 1) Dissolve 24.6 grams of analytical grade potassium chloride (KCl) reagent in 100 ml distilled water.
- 2) Add pH 4.01 standard buffer and adjust solution to pH 4.

## 7.7 ORP Calibration and mV Measurement

### 7.7.1 Prior Use

#### 1) Connecting the Electrode.

- Select a suitable ORP electrode.
- Insert the BNC connector into the connector socket on meter, rotate and push the connector clockwise until it locks.

After connection is completed, do not pull on the sensor cable. Always make sure that the connector is clean and dry.

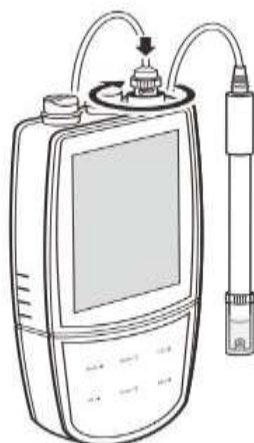

Figure-36

- Remove the protective cap from the bottom of the electrode.

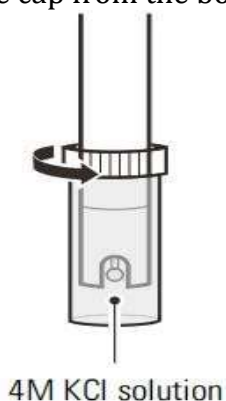
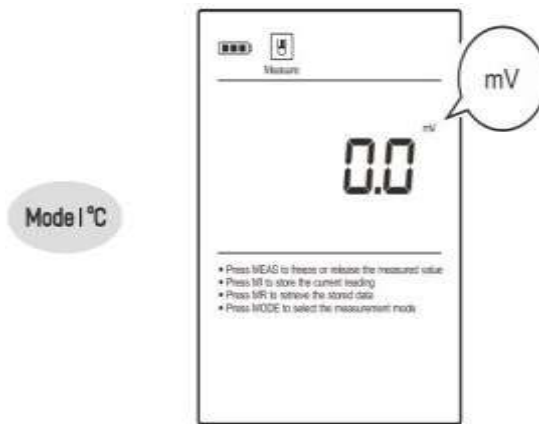

Figure-37

#### 2) Selecting the Measurement Mode

- Raw millivolt (mV)

Press the **Mode** key until the measurement unit mV appears on the display, the meter enters the absolute mV measurement mode.



**Figure-38**

- Relative millivolt (R.mV)  
Press the Mode key until the **ORP** icon appears on the display; the meter enters the relative mV measurement mode.

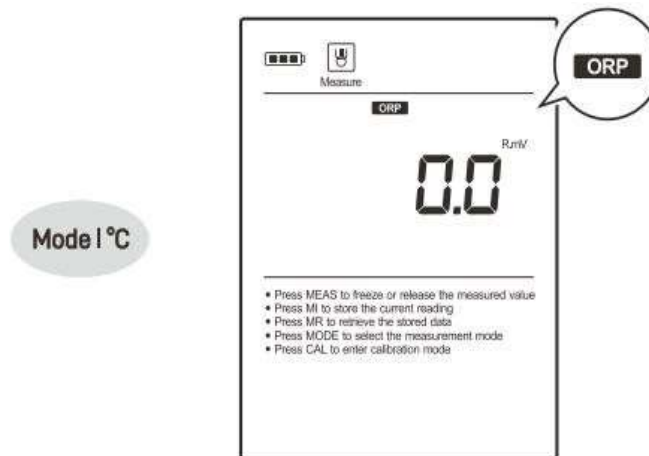

**Figure-39**



Note, the meter only allows entering the setup menu or performing a calibration or viewing the calibration login the **ORP** mode.

## 7.7.2 ORP Settings

Menu Item	Option and Description
	<b>Resolution</b>
	Set the resolution of the mV measurement.
RESO	0.1 0.1 (default)
	1 1

**Figure-40**

The meter contains 1 ORP setting and 7 general settings in the setup menu.

If you want to change the current settings, press and hold the  key to enter the setup menu. Press the  /  key to select an option and press the Enter key to confirm.

### 7.7.3 mV Measurement

- 1) Rinse the ORP electrode with distilled water. Place the electrode into the sample solution and stir gently. **Note**, the sensing element and liquid junction must be completely immersed into the solution.

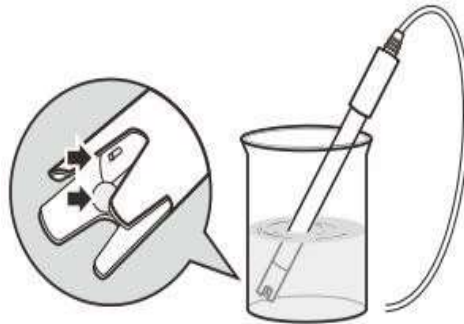



Figure-41

- 2) If the Auto-Hold option in the setup menu is enabled, the meter will automatically sense a stable reading and lock measurement, the **HOLD** icon appears on the display. Press the  key to resume measuring.

If the option is disabled, the meter will continuously measure and update the readings.

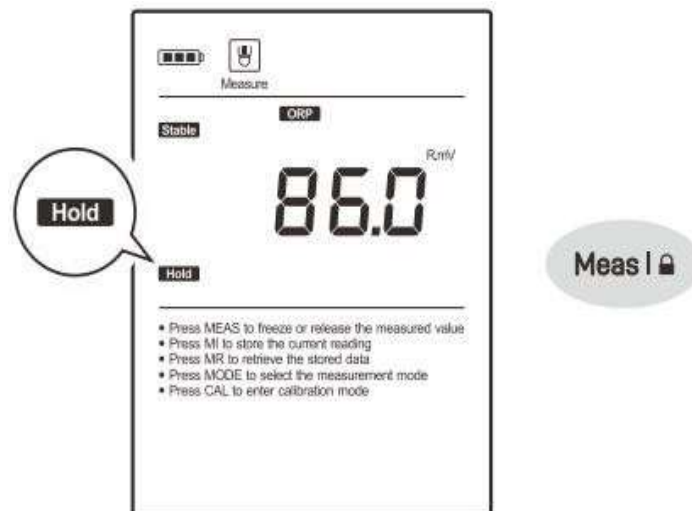

Figure-42

- 3) Wait for the measurement to stabilize and record the reading.
- 4) When all of the samples have been measured, rinse the electrode with distilled water and soak in 4M KCl solution.

- The ORP electrode may give unstable readings in solutions that contain chromous, vanadous and titanous ions or other ions that are stronger reducing agents than hydrogen or platinum.
- If the meter shows indicating the measurement exceeds the range, remove the electrode from the sample immediately.
- To record the measurement at the predefined time intervals, refer to the Interval Readings section.

## 7.7.4 ORP Calibration

The meter allows 1 point calibration in the ORP mode, but calibration is not necessary unless exact readout agreement with a work standard and at a specific ORP value is needed.

- 1) Rinse the ORP electrode with distilled water. Place the electrode into the standard solution, stir gently and wait until the measurement is stable.

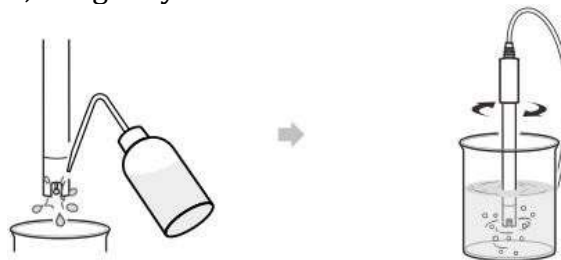

Figure-43

- 2) Press the **Cal** key, the meter enters the calibration mode.



Figure-44

- 3) If necessary, press the **▲ / ▼** key to set the calibration value.
- 4) Press the **Enter** key, the meter will show **End** and return to the measurement mode. Calibration is completed.

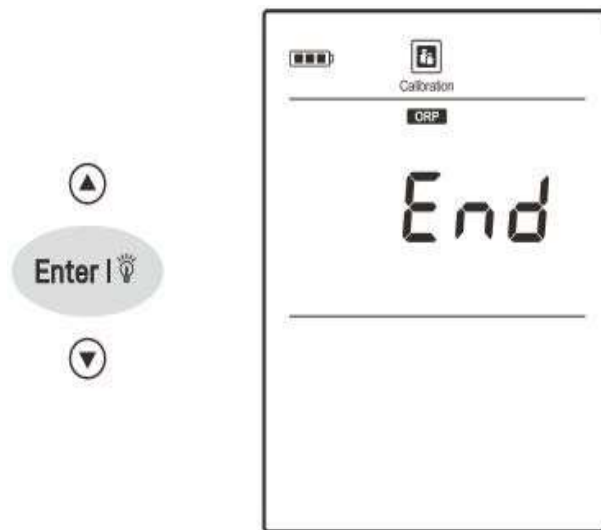

Figure-45

To exit the calibration without saving changes, press the Meas key.

#### 7.7.4.1 Viewing the calibration Log

- 1) Press the **MR** key in the ORP measurement mode and press the **▼** key until the meter shows *ELE/P-02* (Electrode).
- 2) Press the **Enter** key, the meter shows the last calibration date.

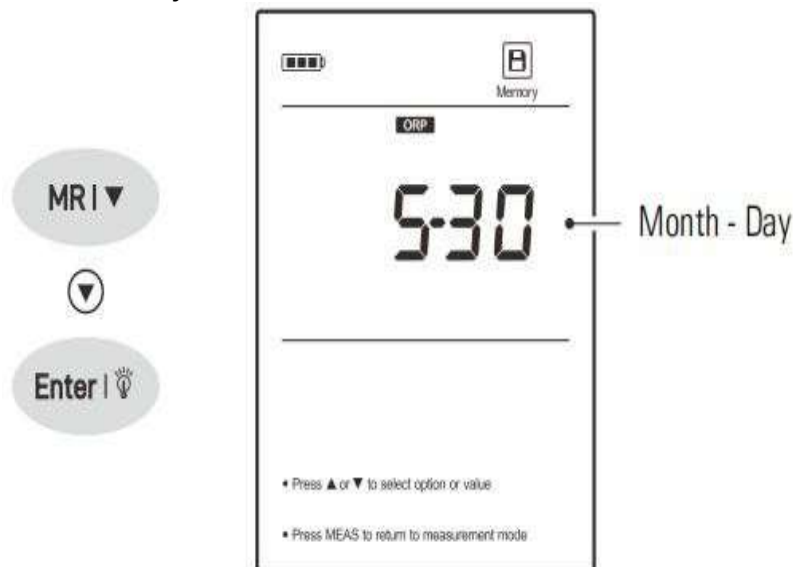
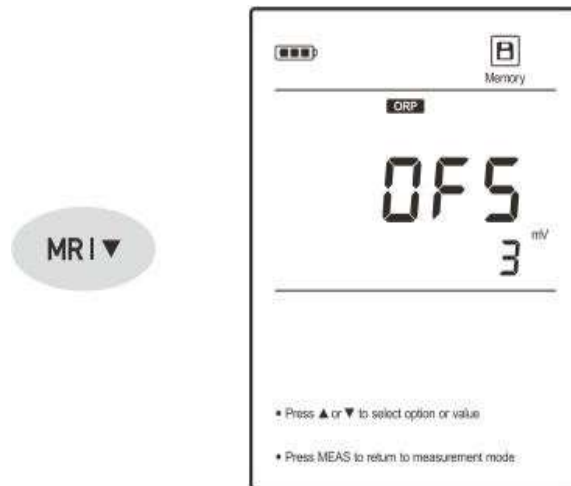

Figure-46

- 3) Press the **▼** key to view the offset potential.



**Figure-47**

- 4) To exit the calibration log, press the **Meas** key.  
If the meter is not calibrated with standard solution, the display will show only.

### 7.7.5 Electrode Maintenance

- Rinse the ORP electrode thoroughly with distilled water after use.
- In the corrosive chemicals, viscous solutions and solutions with heavy metals or proteins, take readings quickly and rinse electrode immediately.
- If the electrode response becomes sluggish, refer to the instructions below to clean the electrode.

#### **Inorganic Deposits**

- Place the electrode in 0.1M HCl solution for 10 minutes. Rinse the electrode with distilled water and soak in 4M KCl solution for at least 6 hours.

#### **Oil or Grease**

- Place the electrode in detergent such as dishwashing liquid for about 30 minutes. Rinse the electrode with distilled water and soak in 4M KCl solution.
- If the platinum sensing element is severely contaminated, polish the platinum surface gently with an abrasive paper of 600 grid. Place the electrode in 0.1M HCl solution for 10 minutes. Remove and rinse with distilled water, then soak in 4M KCl solution for at least 6 hours.
- If the electrode does not restore normal performance, replace the electrode.

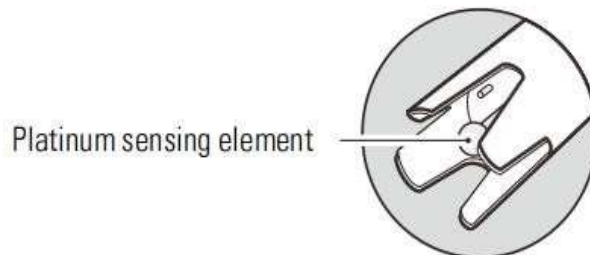

**Figure-48**

## 7.7.5.1 Storing the ORP Electrode

If user do not use the electrode for long periods, store the electrode in 4M KCl solution or storage solution.

## 7.7.5.2 Preparation of ORP Standard Solutions

**Quinhydrone solution A:** Dissolve 3 grams of quinhydrone reagent 500 ml of the pH 4.01 buffer solution, stir the solution for 10 minutes. An undissolved quinhydrone reagent must be present. If necessary, add the reagent.

Temperature	Potential ( $\pm 10$ mV)
20°C	268 mV
25°C	263 mV
30°C	260 mV

**Quinhydrone solution B:** Dissolve 3 grams of quinhydrone reagent in 500 ml of the pH 7.00 buffer solution, stir the solution for 10 minutes. An undissolved quinhydrone reagent must be present. If necessary, add the reagent.

Temperature	Potential ( $\pm 10$ mV)
20°C	94 mV
25°C	87 mV
30°C	80 mV

Due to the quinhydrone solution that is susceptible to air oxidation in storage, make sure to prepare the fresh solution before use.

## 7.7.5.3 Preparation of Electrode Storage Solution

- Dissolve 29.8 grams of analytical grade potassium chloride (KCl) reagent in 100 ml distilled water.
- Add pH 4.01 standard buffer and adjust solution to pH 4.

## 7.8 Ion Calibration and Measurement

### 7.8.1 Prior to use

- Takeout the ion selective electrode from the carrying case.
- Remove the protective cap and soak the electrode in 100 ppm standard solution for 10 minutes.

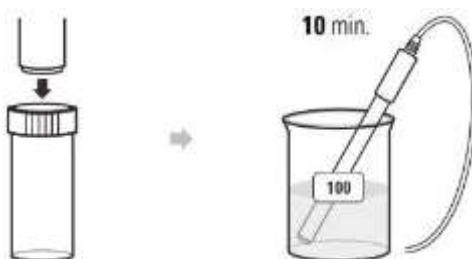

**Figure-49**

## 7.8.1.1 Connecting the Electrode

Insert the BNC connector into the connector socket on meter, rotate and push the connector clockwise until it locks.

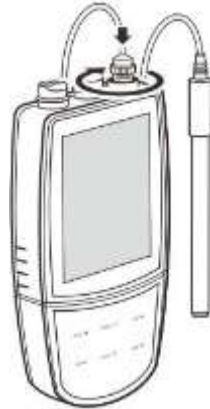

Figure-50

After connection is completed, do not pull on the sensor cable. Always make sure that the connector is clean and dry.

## 7.8.1.2 Selecting the Measurement Mode

Press the Mode key until the **ION** icon appears on the display; the meter enters the ion concentration measurement mode.

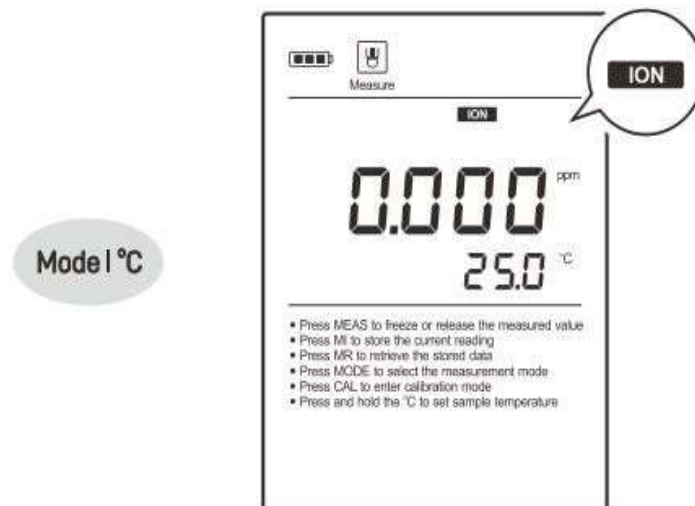



Figure-51

## 7.8.2 Ion Settings

The meter contains 3 ion settings and 7 general settings in the setup menu.

Menu Item	Option and Description
	<b>Measurement Unit</b> Set the ion concentration and temperature units.
UNIT	ppm      Parts per million (default)
	mg/L     Milligrams per liter
	mol/L    Moles per liter
	°C        Degrees Celsius (default)
	°F        Degrees Fahrenheit
	<b>Calibration Points</b> Set the number of calibration points.
CAL	...5      2 to 5 points (default 2 points)
	<b>Ionic Valency</b> Set the ion valence of electrode.
ION	1         Monovalent (default)
	2         Divalent

If User wants to change the current settings, press and hold the  key to enter the setup menu. Press the  key to select an option and press the **Enter** key to confirm.

If the ion concentration unit has converted, the meter will show CRL always and wait for calibration. Press the Cal key and refer to the Ion Calibration section to perform the calibration, the meter will switch to selected concentration unit when calibration is completed.

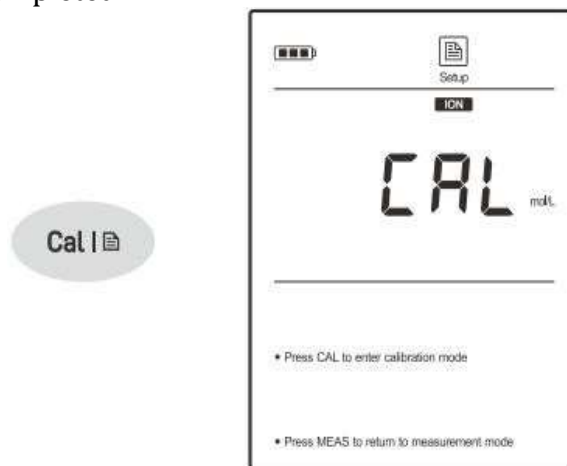

**Figure-52**

### 7.8.3 Temperature Compensation

Due to the temperature difference between the standard and sample solutions will cause approximately 2% measurement error for every degree centigrade of temperature change, we recommend enabling the temperature compensation during the calibration and measurement.

#### Automatic Temperature Compensation

Connect the temperature probe to meter, the ATC icon appears on the display, the meter is now switched to the automatic temperature compensation mode.



**Figure-53**

#### Manual Temperature Compensation

If the meter does not detect a temperature probe, the degrees Celsius icon (°C) will show on the display indicating the meter is switched to the manual temperature compensation mode. To set the temperature value follow the steps below.

- 1) Press and hold the °C key to enter the temperature setting.
- 2) Press the ▲ / ▼ key to modify the temperature value.
- 3) Press the Enter key to save.

Press and hold the ▲ / ▼ key will make the value change faster.

### 7.8.4 Ion Calibration

The meter allows 2 to 5 points calibration in the ion mode; acceptable calibration points include the following options.

Measurement Unit	Calibration Points
ppm	0.001, 0.01, 0.1, 1, 10, 100, 1000, 10000
mg/L	0.001, 0.01, 0.1, 1, 10, 100, 1000, 10000
mol/L	0.001, 0.01, 0.1, 1, 10
mmol/L	0.001, 0.01, 0.1

- Before beginning the calibration, ensure that the ionic valency option in the setup menu matches connected electrode. All the standards and samples should be at the same temperature and calibration points cover the anticipated range of the samples.

- For the low concentration or sample contains the interference ions, we recommend adding the ionic strength adjuster (ISA) to all the standards and samples. Atypical addition would be 2 ml ISA to 100 ml of standard and sample.
- For the low-level sodium determination (< 1 ppm), make sure to use the laboratory plastic beaker as a container.
- Stir the standards and samples at a uniform rate that will help you get most accurate readings.

## 7.8.4.1 Calibrating the meter

- Press the **Cal** key, the meter shows 0.001 ppm/CAL1 or mg/L, mol/L, mmol/L, depending on the selected concentration unit.
- Press the **▲** key to select first calibration point (e.g., 100 ppm), the meter will automatically perform the calibration from the low to high concentrations.

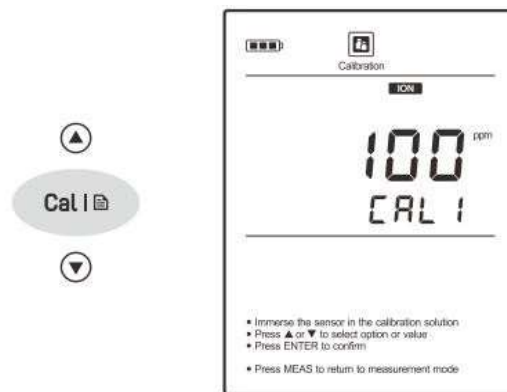

Figure-54

- Rinse the ion selective electrode with distilled water, then rinse with a small amount of standard solution. Place the electrode (and temperature probe) into the standard solution, stir gently to create a homogeneous solution.
- Press the **Enter** key, the Calibration icon begins flashing.

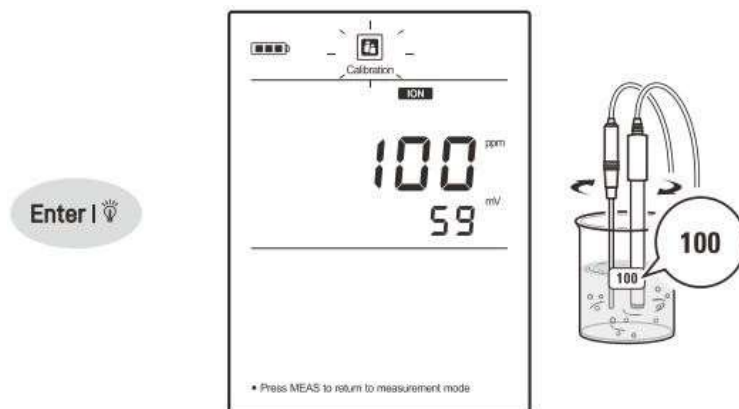

Figure-55

- When the reading has stabilized, the display will show 1000 ppm / CAL2. The meter prompts you to continue with second point calibration.



**Figure-56**

- Rinse the ion selective electrode with distilled water, then rinse with a small amount of standard solution. Place the electrode (and temperature probe) into the next standard solution and stir gently.



**Figure-57**

- Press the Enter key, the Calibration icon begins flashing.

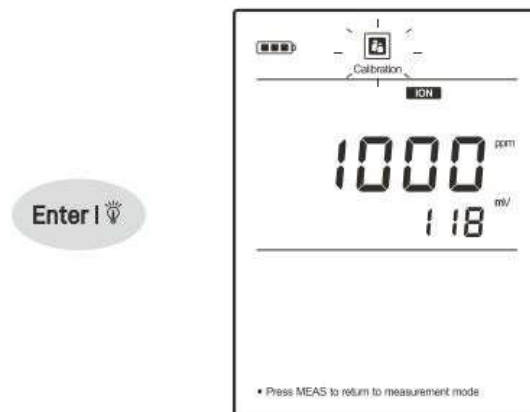

**Figure-58**

- When the reading has stabilized, the display will show CAL3. The meter prompts you to continue with third point calibration.
- Repeat the steps 6 and 7<sup>th</sup> point above until the meter shows *End*. Calibration is completed.

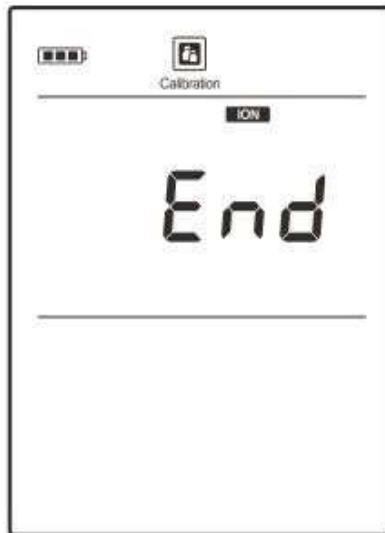

Figure-59

- To exit the calibration without saving changes, press the Meas key.
- 7.8.4.2 Viewing the Calibration Log**
- Press the **MR** key in the ion measurement mode and press the **▼** key until the meter shows *ELE/P-02* (Electrode).
  - Press the **Enter** key, the meter shows the last calibration date.

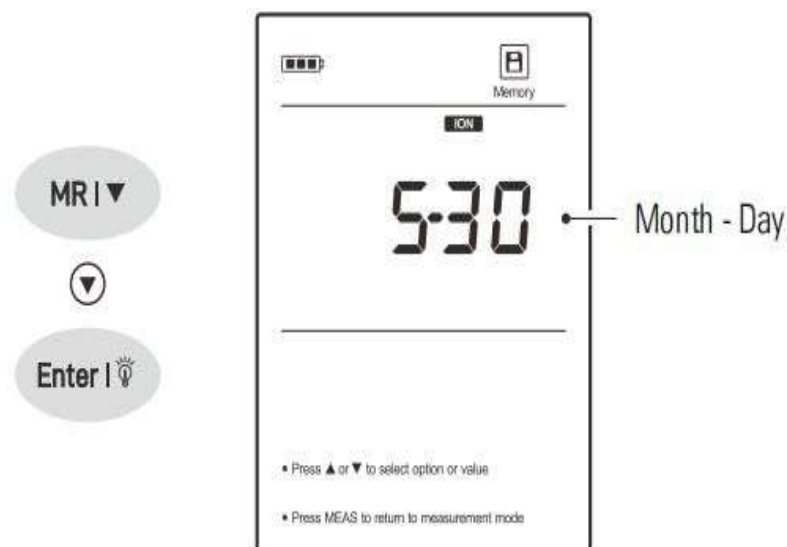
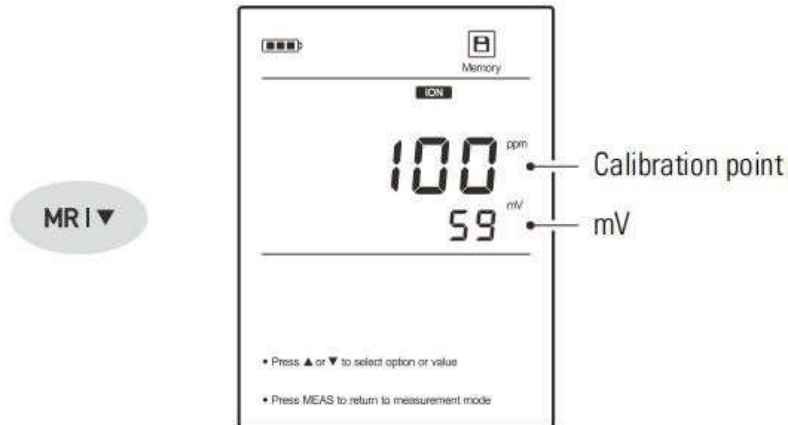

Figure-60

- Press the ▼ key to view the calibration point and mV value.

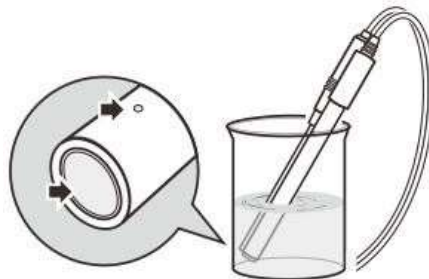

**Figure-61**

- Press the ▼ key to view the next data set.
- To exit the calibration log, press the Meas key.
- If the meter is not calibrated with standard solutions, the display will show only.

## 7.8.5 Ion Measurement

- Rinse the ion selective electrode with distilled water. Place the electrode (and temperature probe) into the sample solution and stir gently. Note, the ion sensitive membrane and liquid junction must be completely immersed into the solution.



**Figure-62**

- If the Auto-Hold option in the setup menu is enabled, the meter will automatically sense a stable reading and lock measurement, the **HOLD** icon appears on the display. Press the  key to resume measuring. If the option is disabled, the meter will continuously measure and update the readings.

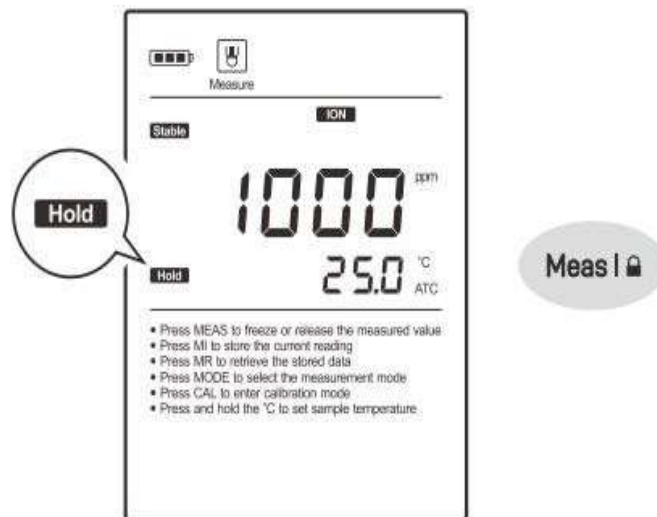
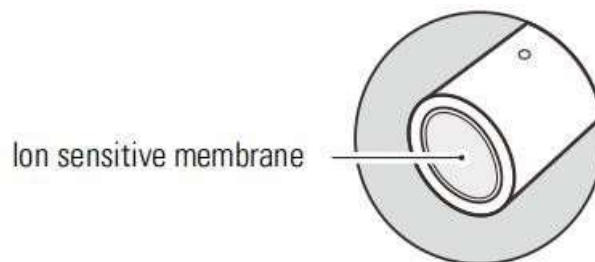

**Figure-63**

- Wait for the measurement to stabilize and record the reading.
- When all the samples have been measured, rinse the electrode with distilled water.
  - During the measurement process, never wipe the ion sensitive membrane, blot dry with a lint-free tissue to remove waterdrops on electrode.
  - If the meter is not calibrated with connected electrode, the display will always show 0.000.
  - If the meter shows--indicating the measurement exceeds the range, remove the electrode from the sample immediately.
  - To record the measurement at the predefined time intervals, refer to the Interval Readings section.

### 7.8.6 Electrode Maintenance

- Rise the ion selective electrode thoroughly with distilled water after use, wipe clean with a lint-free tissue, then replace
- protective cap and store the electrode in a dry, cool and well-ventilated area.
- Never scratch the ion sensitive membrane on the bottom of the electrode.
- If the electrode response becomes sluggish, soak the electrode in 100 ppm standard solution for at least 1 hour.



**Figure-64**

## 7.8.7 Appendix

Preparation of Ion Standard Solution (1000 ppm)

- 1) Half fill a 1-liter volumetric flask with distilled water and add the analytical grade reagent according to the instructions in table below.

Ion Type	Reagent	Weight
Ammonium	NH <sub>4</sub> Cl	2.97 g
Bromide	NaBr	1.29 g
Cadmium	Cd(NO <sub>3</sub> ) <sub>2</sub> • 4H <sub>2</sub> O	2.74 g
Calcium	CaCl <sub>2</sub> • 2(H <sub>2</sub> O)	3.67 g
Chloride	NaCl	1.65 g
Cupric	Cu(NO <sub>3</sub> ) <sub>2</sub> • 3H <sub>2</sub> O	3.80 g
Cyanide	NaCN	1.88 g
Fluoride	NaF	2.21 g
Iodide	NaI	1.18 g
Lead	Pb(NO <sub>3</sub> ) <sub>2</sub>	1.60 g
Nitrate	NaNO <sub>3</sub>	1.37 g
Potassium	KCl	1.91 g
Silver	AgNO <sub>3</sub>	1.57 g
Sodium	NaCl	2.54 g
Sulfide	Na <sub>2</sub> S • 9H <sub>2</sub> O	7.49 g
Ammonia	NH <sub>4</sub> Cl	3.15 g

- 2) Swirl the volumetric flask gently to dissolve the reagent and fill to the mark with distilled water.
- 3) Cap and upend the volumetric flask several times to mix the solution.

## 7.9 Conductivity TDS/Salinity/Resistivity calibration and measurement

### 7.9.1 Prior to Use

- Takeout the conductivity electrode from the carrying case.
- Soak the electrode for about 10 minutes in tap water to remove dirt and oil stains on the sensor surface.



**Figure-65**

## 7.9.1.1 Connecting the Electrode

Insert the 6-pin connector into the connector socket on meter; ensure the connector is fully seated.



Figure-66

After connection is completed, do not pull on the sensor cable. Always make sure that the connector is clean and dry.

## 7.9.1.2 Selecting the measurement mode

Press the **Mode** key, the meter will show the conductivity (COND), TDS, salinity (SAL) and resistivity (RES) icons. Select a desired mode.

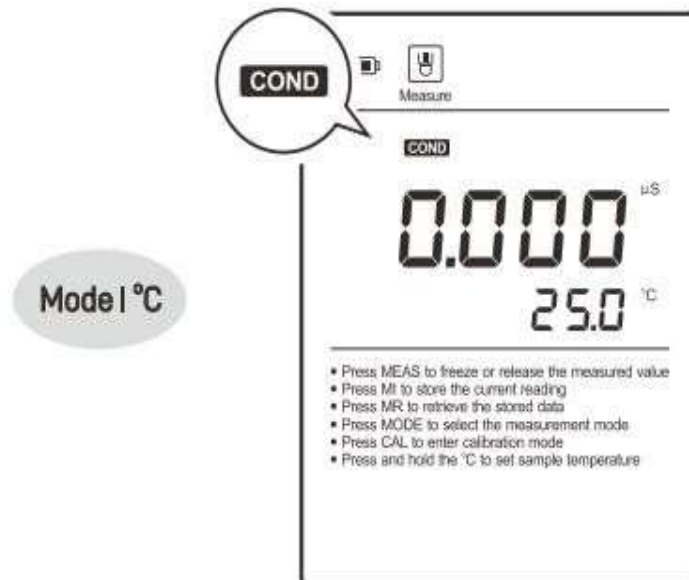

Figure-67

## 7.9.2 Conductivity /TDS/Salinity Settings

The meter contains 7 conductivity/TDS settings and 7 general settings in the setup menu.

Menu Item	Option and Description
	<b>Cell Constant</b> Set the cell constant to match connected conductivity electrode.
CELL	0.1      K = 0.1
	1         K = 1 (default)
	10        K = 10
	USER     Custom
	<b>Temperature Coefficient</b> Set the temperature coefficient for linear temperature compensation.
COE	2.10      0.00 to 10.00%/°C (default 2.10)
	<b>Calibration Points</b> Set the number of calibration points.
CAL	...5      1 to 5 points (default 1 point)
	<b>Pure Water Compensation</b> If enabled, the pure water compensation coefficient will be applied automatically for ultra-pure water measurements.
PURE	YES      Enable
	NO        Disable (default)
	<b>Reference Temperature</b> Set the normalization temperature for measurement, the readings will automatically compensate to the selected temperature during measurement.
SEd	25°C     25°C (default)
	20°C     20°C
	<b>TDS Factor</b> Set the default TDS conversion factor.
TdS	0.50      0.40 to 1.00 (default 0.50)
	<b>Measurement Unit</b> Set the default temperature unit.
UNIT	°C        Degrees Celsius (default)
	°F        Degrees Fahrenheit

If User want to change the current settings, press and hold the key to enter the setup menu. Press the ▲ / ▼ key to select an option and press the Enter key to confirm.

### 7.9.3 Temperature Compensation

The temperature compensation has a large effect on conductivity measurement. If enabled, the meter will use the measured conductivity and temperature readings to calculate the result and automatically compensate for the selected reference temperature. If the temperature coefficient is set to 0, the temperature compensation will be disabled, the meter only shows the actual conductivity at the measured temperature.

#### Automatic Temperature Compensation

Connect the temperature probe to meter, the ATC icon appears on the display, the meter is now switched to the automatic temperature compensation mode.



**Figure-68**

#### Manual Temperature Compensation

If the meter does not detect a temperature probe, the degrees Celsius icon (°C) will show on the display indicating the meter is switched to the manual temperature compensation mode. To set the temperature value follow the steps below.

- 1) Press and hold the °C key to enter the temperature setting.
- 2) Press the ▲ / ▼ key to modify the temperature value.
- 3) Press the Enter key to save.

Press and hold the ▲ / ▼ key will make the value change faster.

### 7.9.4 Selecting a Conductivity Electrode

The meter can connect the three types of conductivity electrodes. Before the calibration and measurement, ensure that you have selected a suitable electrode according to the anticipated sample conductivity. The following table lists the selectable electrode and its effective measurement ranges.

Electrode	Measurement Range	Cell Constant
CON-0.1	0.5 to 100 $\mu$ S/cm	K = 0.1
CON-1	10 $\mu$ S/cm to 20 mS/cm	K=1
CON-10	100 $\mu$ S/cm to 200 mS/cm	K = 10

## 7.9.5 Conductivity Calibration

### Automatic Calibration

The meter allows 1 to 5 points calibration in the conductivity mode. Before calibration, ensure that selected cell constant (K = 0.1, 1, 10) matches connected electrode. If you have selected the manual calibration (**USER**), the meter will wait to enter a cell constant.

For better accuracy, we recommend performing 3 points calibration or selecting a standard solution close to the sample conductivity you are measuring. The meter will automatically detect the standard solution and prompt the user to perform the calibration.

The following table shows the default standard solution for each measurement range.

Measurement Range	Default Standard Solution
0 to 20 $\mu\text{S}/\text{cm}$	10 $\mu\text{S}/\text{cm}$
20 to 200 $\mu\text{S}/\text{cm}$	84 $\mu\text{S}/\text{cm}$
200 to 2000 $\mu\text{S}/\text{cm}$	1413 $\mu\text{S}/\text{cm}$
2 to 20 $\text{mS}/\text{cm}$	12.88 $\text{mS}/\text{cm}$
20 to 200 $\text{mS}/\text{cm}$	111.8 $\text{mS}/\text{cm}$

If you have changed the conductivity electrode, the meter must be recalibrated. Every electrode has a different cell constant.

### Single Point Calibration

- 1) Press the **Mode** key to enter the conductivity measurement mode and select 1 point calibration in the setup menu.
- 2) Press the **Cal** key, the display shows /CAL1, the meter waits for recognizing the standard solution.

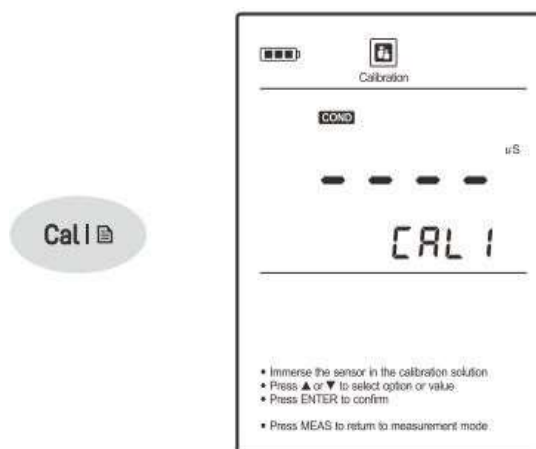
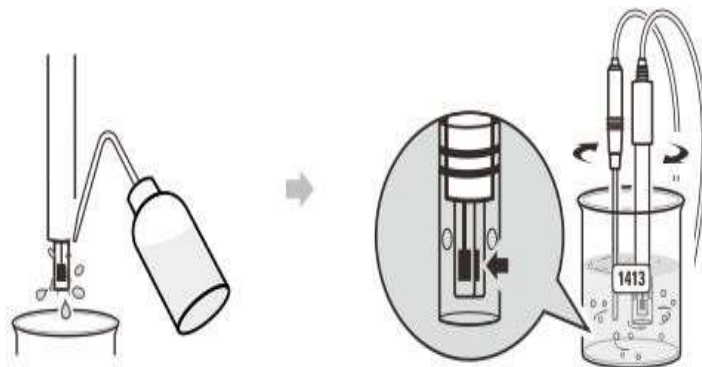

Figure-69

- 3) Rinse the conductivity electrode with distilled water, then rinse with a small amount of standard solution. Place the electrode (and temperature probe) into the standard solution, stir gently to remove air bubbles trapped in the slot of the sensor.



**Figure-70**

The meter will automatically show the calibration standard (e.g., 1413  $\mu$ S/cm).



**Figure-71**

- 4) If necessary, press the ▲ / ▼ key to modify the calibration value. Press the **Enter** key, the Calibration icon begins flashing.

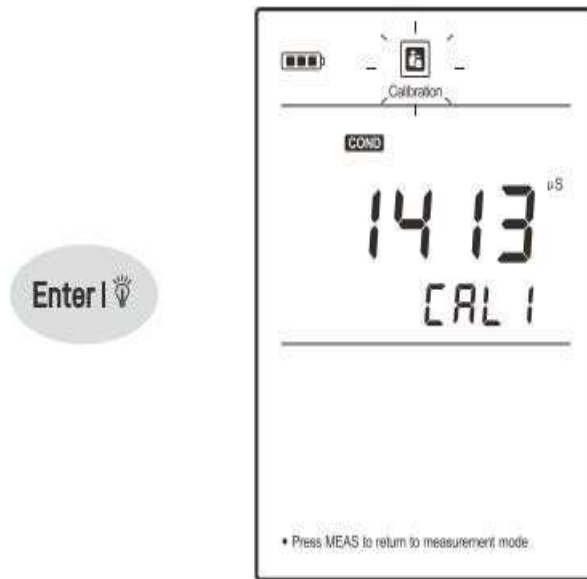

**Figure-72**

- 5) When the reading has stabilized, the meter will show End and return to the measurement mode.

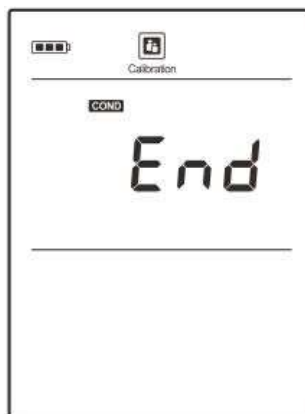



**Figure-73**

### **Multipoint Calibration**

- Ensure that you have selected 2 to 5 points calibration in the setup menu. When the first calibration point is completed, the display will show /CAL2. The meter prompts you to continue with second point calibration.
- Repeat steps 3 and 4 in calibrating the meter above until the meter shows End. Calibration is completed.



## Manual Calibration

The meter provides an easy manual calibration mode. If the conductivity standard solution is not ready, you are able to use this method to calibrate the meter.

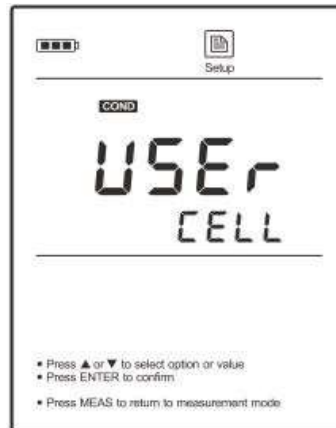
- 1) Press and hold the  key to enter the setup menu.
- 2) Press the Enter key, the display shows *1/CELL*.
- 3) Press the  /  key to select *USER/CELL*.

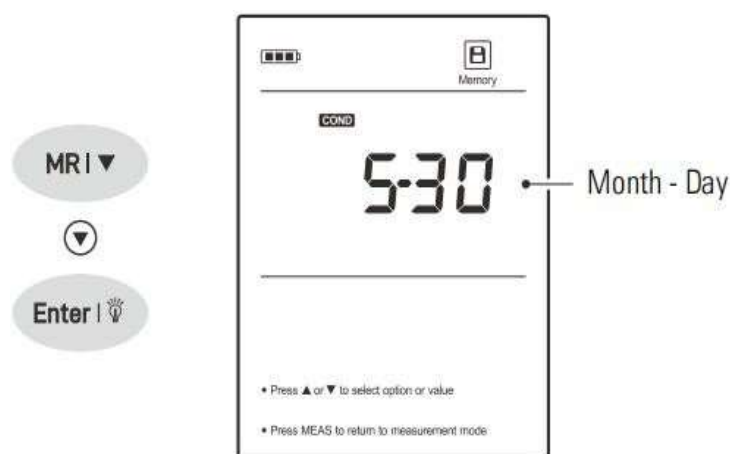

**Figure-74**

- 4) Press the **Enter** key, the first digit begins flashing.
- 5) Press the  /  key to set the cell constant, press the Enter key to save until the meter returns to the measurement mode.
  - Performing the conductivity calibration will simultaneously calibrate the corresponding TDS, salinity and resistivity values.
  - To exit the calibration without saving changes, press the **Meas** key.

## Viewing the Calibration Log

- 1) Press the **MR** key in the measurement mode and press the  key until the meter shows (Electrode).
- 2) Press the **Enter** key, the meter shows the last calibration date.



**Figure-75**

- 3) Press the ▼ key to view the calibration point and cell constant (e.g., 0.998).

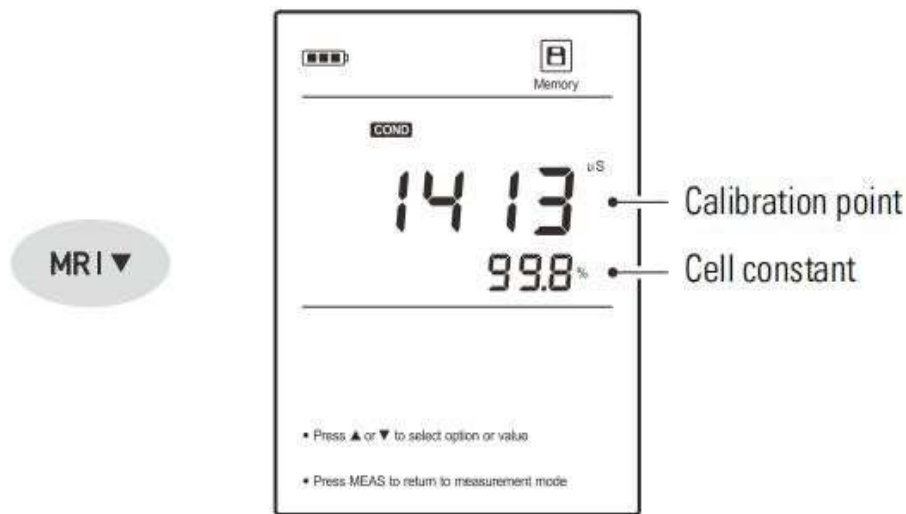
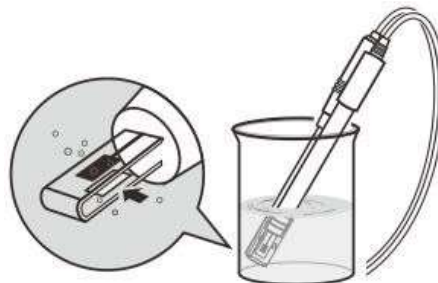

**Figure-76**

- 4) Press the ▼ key to view the next data set.  
5) To exit the calibration log, press the Meas key.  
If the meter is not calibrated with standard solution, the display will show only.

## 7.9.6 Measurements

- 1) Press the Mode key to select the measurement mode.
  - In the total dissolved solids (TDS) mode, ensure that you have set a correct conductivity-to-TDS conversion factor in the setup menu (default 0.50).
  - In the salinity mode **SAL**, the meter provides 2 measurement units. When the PSU appears on the right of the measurement value indicating the meter is in the practical salinity measurement mode. When the ppt appears on the display indicating the meter is in the natural seawater measurement mode.
- 2) Rinse the conductivity electrode with distilled water. Place the electrode (and temperature probe) into the sample solution and stir gently. Ensure that no air bubbles on the sensor surface.



**Figure-77**

- 3) If the Auto-Hold option in the setup menu is enabled, the meter will automatically sense a stable reading and lock measurement, the **HOLD** icon appears on the display. Press the **Hold** key to resume measuring. If the option is disabled, the meter will continuously measure and update the readings.

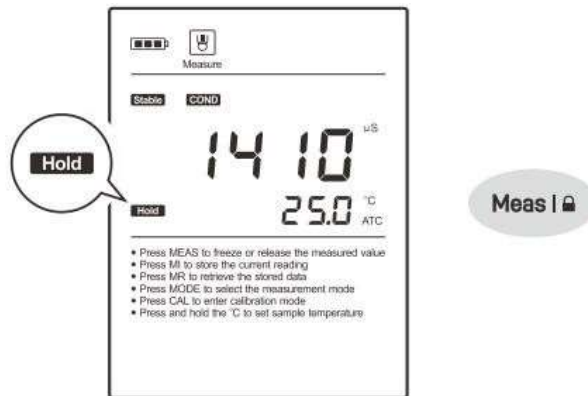

Figure-78

- 4) Wait for the measurement to stabilize and record the reading.
- 5) When all the samples have been measured, rinse the electrode with distilled water.
- If the meter show-indicating the measurement exceeds the range, replace a conductivity electrode that is appropriate for the conductivity range of the sample solution you are measuring.
  - To record the measurement at the predefined time intervals, refer to the Interval Readings section.

### 7.9.7 Electrode Maintenance

- Rinse the conductivity electrode thoroughly with distilled water after use.
- Do not touch the platinum black coating on the sensor surface and always keep it clean.
- If there is a build-up of solids inside the sensor, remove carefully, then recalibrate the electrode.
- If you do not use the electrode for long periods, wipe clean with a lint-free tissue and store the electrode in a dry and cool area.
- If your electrode is , store the electrode with tap water. This sensor needs to be kept wet always.

### 7.9.8 Appendix

#### Preparation of Conductivity Standard Solutions

- 1) Place the analytical grade potassium chloride (KCl) in a beaker and dry in an oven for about 3 hours at 105°C (221°F), then cool to room temperature.
- 2) Add the reagent to a 1 liter volumetric flask according to the instructions in table below.

Conductivity Standard	Reagent	Weight
84 $\mu$ S/cm	KCl	42.35 mg
1413 $\mu$ S/cm	KCl	745.5 mg
12.88 mS/cm	KCl	7.45 g
111.8 mS/cm	KCl	74.5 g

- 3) Fill the distilled water to the mark, mix the solution until the reagent is completely dissolved.

### Calculating the Cell Constant

- 1) Refer to the Manual Calibration in 8.9.5 to set the cell constant to 1.000.
- 2) Place the electrode into a standard solution and record the reading.
- 3) Calculate the cell constant using the following formula.

$$K = (C_{std} / C_{meas}) \times G$$

Where:

K = Cell constant

C<sub>std</sub> = Value of conductivity standard solution

C<sub>meas</sub> = Measured value

G = Raw cell constant (0.1, 1 or 10)

### Calculating the Temperature Coefficient

- 1) Do not connect the temperature probe to the meter.
- 2) Press and hold the °C key to enter the temperature setting.
- 3) Press the ▲ / ▼ key to set the temperature to 25°C and press the Enter key to confirm.
- 4) Place the conductivity electrode into the sample solution, record the temperature value TA and conductivity value CTA.
- 5) Condition the sample solution and electrode to a temperature TB that is about 5 to 10°C different from TA. Record the conductivity value CTB.
- 6) Calculate the temperature coefficient using the formula below.

$$T_C = [C_{TB} - C_{TA}] / [C_{TA}(T_B - 25) - C_{TB}(T_A - 25)]$$

Where:

T<sub>C</sub> = Temperature coefficient

C<sub>TA</sub> = Conductivity at temperature A

C<sub>TB</sub> = Conductivity at temperature B

T<sub>A</sub> = Temperature A T<sub>B</sub> = Temperature B

### Calculating the TDS Conversion Factor

To determine the TDS factor of sample solution, use the formula below. Factor = Actual TDS / Actual Conductivity @25°C.

Where:

- Actual TDS = value from the high purity water and precisely weighed NaCl or KCL reagent
- Actual Conductivity = the meter measured conductivity value

For example:

Dissolve 64 grams of potassium chloride (KCl) in 1-liter distilled water. If the measured conductivity is 100 mS/cm, then the TDS factor is 0.64.

### Conductivity to TDS Conversion Factors

Conductivity at 25°C	TDS (KCl)		TDS (NaCl)	
	ppm	Factor	ppm	Factor
84 $\mu$ S/cm	40.38	0.5048	38.04	0.4755
1413 $\mu$ S/cm	744.7	0.527	702.1	0.4969
12.88 mS/cm	7447	0.5782	7230	0.5613

## 7.10 Dissolved Oxygen Calibration and Measurement

### 7.10.1 Prior to use

#### 7.10.1.1 Filling the Electrolyte Solution

- 1) Takeout the dissolved oxygen electrode and electrolyte solution from the packaging. Unscrew the membrane cap from the bottom of the electrode, rinse the inside and outside with distilled water and blot dry.
- 2) Fill the membrane cap halfway with electrolyte solution.



**Figure-79**

- 3) Screw membrane cap back onto the electrode. Some electrolyte solution will overflow during this process.
- 4) Check the electrode, ensure that no air bubbles are trapped in the electrolyte solution and the membrane is not creased or damaged.



**Figure-80**

## 7.10.1.2 Polarizing the Electrode

- Insert the 6-pin connector into the connector socket on meter, ensure the connector is fully seated.
- Switch on the meter and wait 10 minutes for the electrode to polarize.

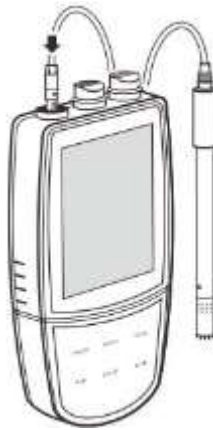
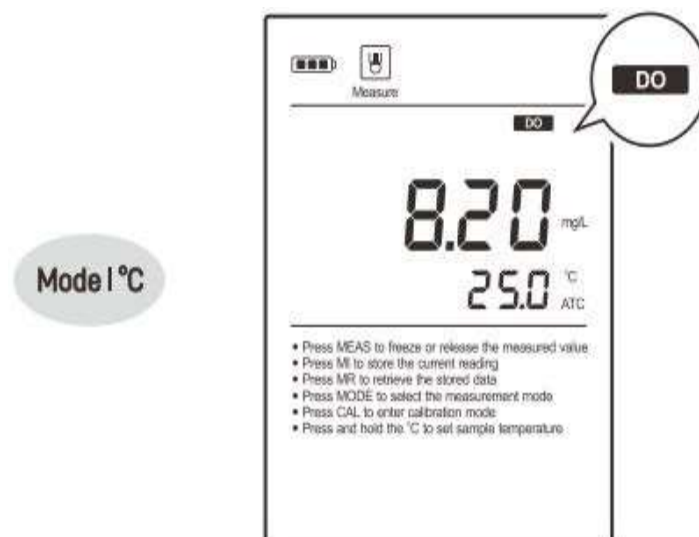

**Figure-81**

The dissolved oxygen electrode must be polarized before use.

## 7.10.1.3 Selecting the Measurement Mode

- Press the Mode key until the **DO** icon and measurement unit mg/L or ppm appears on the display; the meter enters the dissolved oxygen concentration mode.
- Press the key again, the measurement unit will switch to %, the meter enters the percentage saturation mode.



**Figure-82**

## 7.10.2 Dissolved Oxygen Settings

The meter contains 5 dissolved oxygen settings and 7 general settings in the setup menu.

Menu Item	Option and Description
<b>Calibration Points</b>	
Set the number of calibration points.	
CAL	1 1 point
	2 2 points (default)
<b>Pressure Coefficient</b>	
Set the barometric pressure coefficient according to the local altitude.	
PRES	760.0 450.0 to 850.0 mmHg, 60.0 to 113.3 kPa (default 760.0 mmHg, 101.3 kPa)
<b>Salinity Coefficient</b>	
Set the salinity compensation coefficient of sample.	
SAL	0.0 0.0 to 50.0 ppt (default 0.0)
<b>Resolution</b>	
Set the resolution of the dissolved oxygen measurement.	
RESO	0.01 0.01 mg/L, 0.1% (default)
	0.1 0.1 mg/L, 1%
<b>Measurement Units</b>	
Set the default dissolved oxygen, barometric pressure and temperature units.	
UNIT	mg/L Milligrams per liter (default)
	ppm Parts per million
	mmHg Millimeter of mercury (default)
	kPa Kilopascal
	°C Degrees Celsius (default)
	°F Degrees Fahrenheit

- If User wants to change the current settings, press and hold the  key to enter the setup menu. Press the ▲ / ▼ key to select an option and press the **Enter** key to confirm.
- The following table describes the relationship between the altitude and barometric pressure, making sure to set a compatible parameter before the calibration and measurement.
- Press and hold the ▲ / ▼ key will make the value change faster.

## Multi-Parameter Water Quality Meter LB-11PMT

Altitude (m)	kPa	mmHg	Altitude (m)	kPa	mmHg
0	101.3	760	1800	80.9	607
100	100.1	750	1900	79.9	599
200	98.8	741	2000	78.9	592
300	97.6	732	2100	77.9	584
400	96.4	723	2200	76.9	577
500	95.2	714	2300	76.0	570
600	94.0	705	2400	75.0	563
700	92.8	696	2500	74.1	556
800	91.7	688	2600	73.2	549
900	90.5	679	2700	72.3	542
1000	89.4	671	2800	71.4	536
1100	88.3	662	2900	70.5	529
1200	87.2	654	3000	69.6	522
1300	86.1	646	3100	68.7	515
1400	85.0	638	3200	67.9	509
1500	84.0	630	3300	67.0	502
1600	82.9	622	3400	66.2	496
1700	81.9	614	3500	65.4	490

### 7.10.3 Dissolved Oxygen Calibration

- The meter allows 1 or 2 points calibration in the dissolved oxygen mode. If user have selected the 1-point calibration in the setup menu, we recommend that you perform a 100% saturation calibration in the air-saturated water. If the 2 points calibration is selected, the zero-oxygen solution needs to be used.
- During the calibration and measurement, the temperature sensor on electrode must be immersed in solution completely and the solution should keep 0.3 m/s of minimum flow rate to avoid oxygen starvation at the membrane.

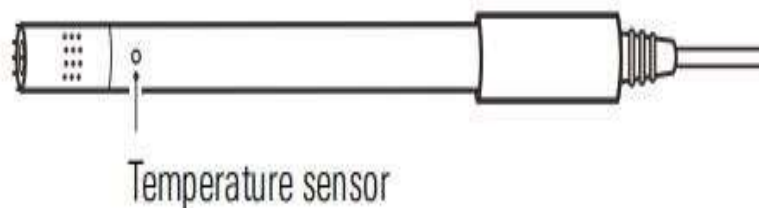

**Figure-83**

#### 7.10.3.1 Do Calibration in mg/L or ppm Mode

- 1) Press the Mode key to enter the dissolved oxygen concentration mode and select the 1-point calibration in the setup menu.
- 2) Press the Cal key, the display shows 8.25 mg/L / CAL1 (@25°C).



**Figure-84**

- 3) Place the dissolved oxygen electrode into the air-saturated water for 10 minutes and stir gently. Press the Enter key, the meter begins the calibration, the Calibration icon continuously flashing.

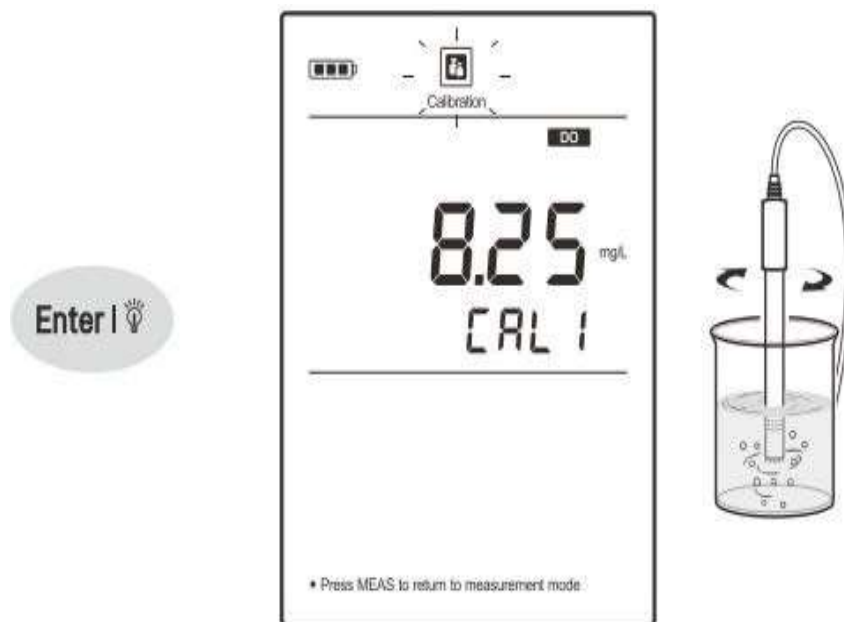

**Figure-85**

- 4) When the reading has stabilized, the meter will show *End* and return to the measurement mode.



**Figure-86**

### 7.10.3.2 Points Calibration

- 1) Ensure that you have selected 2 points calibration in the setup menu.
- 2) Press the Cal key and ▼ key, the meter shows 0.00 mg/L/ CAL1.

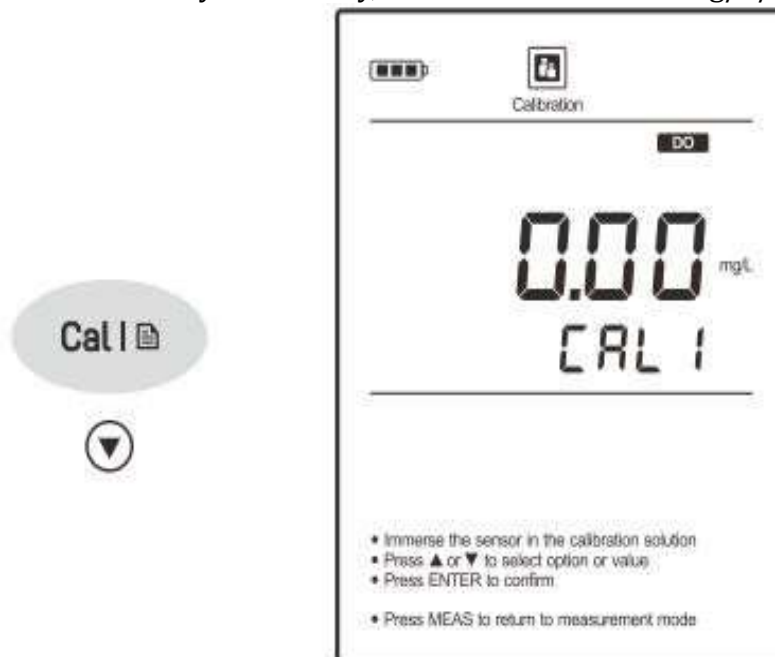

**Figure-87**

- 3) Place the dissolved oxygen electrode into the zero-oxygen solution for about 10 minutes and stir gently. Press the Enter key to begin the calibration.

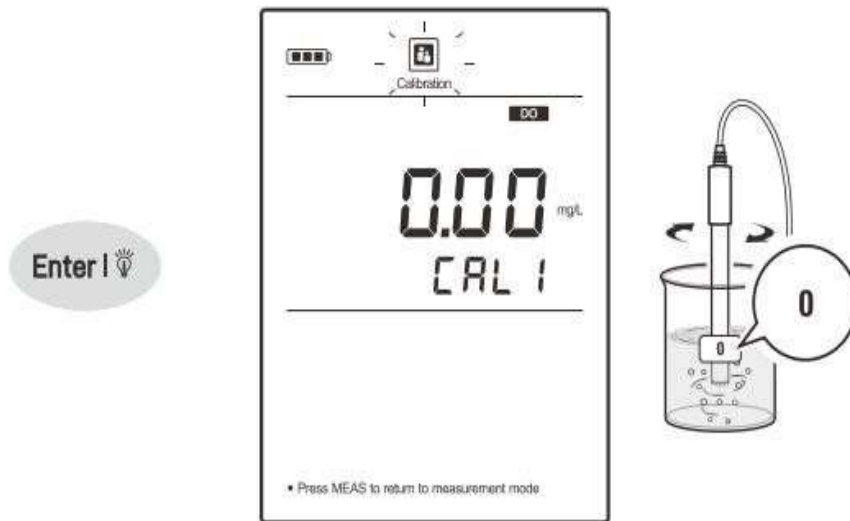

**Figure-87**

- 4) When the reading has stabilized, the display will show 8.25 mg/L / CAL 2 (@25°C). The meter prompts you to continue with second point calibration.
- 5) Repeat the step 3 above until the meter shows **End**. Calibration is completed.

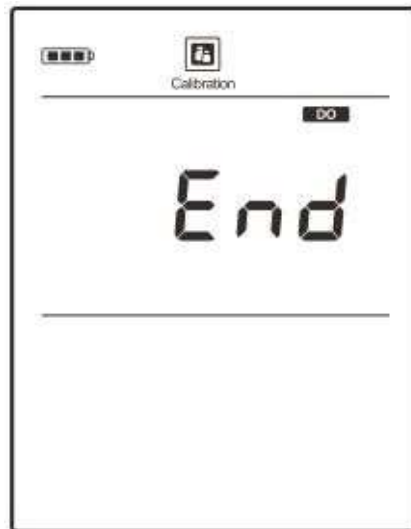

**Figure-88**

### 7.10.3.3 DO Calibration in % Saturation Mode

- 1) Press the **Mode** key to enter the % saturation mode and select the 1-point calibration in the setup menu.
- 2) Press the **Cal** key, the display shows 100.0% / CAL1.
- 3) Hold the dissolved oxygen electrode in the air at 100% relative humidity or place the electrode into the air-saturated water for 10 minutes. Press the Enter key, the meter begins the calibration.
- 4) When the reading has stabilized, the meter will show End and return to the measurement mode.

## 7.10.3.4 2 Points Calibration

- Ensure that you have selected 2 points calibration in the setup menu.
- Press the **Cal** key and the **▼** key, the meter shows 0% / CAL1.
- Place the electrode into the zero-oxygen solution for 10 minutes and stir gently. Press the **Enter** key to begin the calibration.
- When the reading has stabilized, the display will show 100% / CAL2. The meter prompts you to continue with second point calibration.
- Place the electrode into the air-saturated water for 10 minutes and stir gently. Press the **Enter** key to begin the calibration.
- When the reading has stabilized, the meter will show End and return to the measurement mode.

To exit the calibration without saving changes, press the **Meas** key.

## 7.10.4 Dissolved Oxygen Measurement

The meter can be used to measure the water, wastewater, brine and other liquids. If your sample is seawater or water containing large amounts of salt, make sure to set the salinity coefficient before measurement. Some gas and steam such as chloride, sulfur dioxide, sulfured hydrogen and carbon dioxide can permeate the membrane via diffusion. Their existence will influence the measurements. If the sample contains the solvent, grease, sulfide and alga, the membrane will be damaged or eroded.

- 1) Set the barometric pressure and salinity coefficient in the setup menu.
- 2) Rinse the dissolved oxygen electrode with distilled water. Place the electrode into the sample solution and stir gently.
- 3) If the Auto-Hold option in the setup menu is enabled, the meter will automatically sense a stable reading and lock measurement, the **HOLD** icon appears on the display. Press the **Meas** key to resume measuring. If the option is disabled, the meter will continuously measure and update the readings.
- 4) Wait for the measurement to stabilize and record the reading.
  - If the meter shows indicating the measurement exceeds the range, remove the electrode from the sample immediately.
  - To record the measurement at the predefined time intervals, refer to the Interval Readings section.

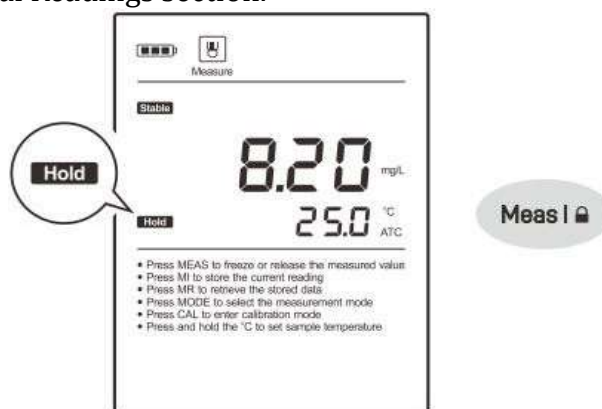

Figure-89

## 7.10.5 Electrode Maintenance

- Rinse the dissolved oxygen electrode thoroughly with distilled water after use.
- Do not touch the membrane and always keep it clean and wet.
- If you do not use the electrode for long periods, screw off the membrane cap and rinse the electrode anode, cathode, membrane cap with distilled water and blot dry. Install the electrode and store dry.

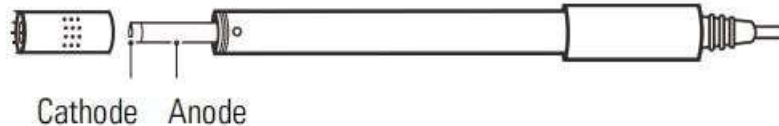

Figure-90

## 7.10.6 Appendix

### Preparation of Zero Oxygen Solution

Dissolve 500 mg of sodium sulfate ( $\text{Na}_2\text{SO}_3$ ) reagent and a small amount of cobalt (II) chloride hexahydrate ( $\text{CoCl}_2 \cdot 6\text{H}_2\text{O}$ ) in the 250 ml distilled water, mix the solution until reagent is completely dissolved.

### Preparation of Air-Saturated Water

Use an air-pump to blow air into distilled water for at least 1 hour, while stirring the solution.

## 7.11 Data Management

### 7.11.1 Data Management

The meter can store and recall up to 500 datasets.

#### 7.11.1.1 Storing a Measurement Result

During the measurement, press the MI key to store the reading into the memory, the Memory icon appears on the display.

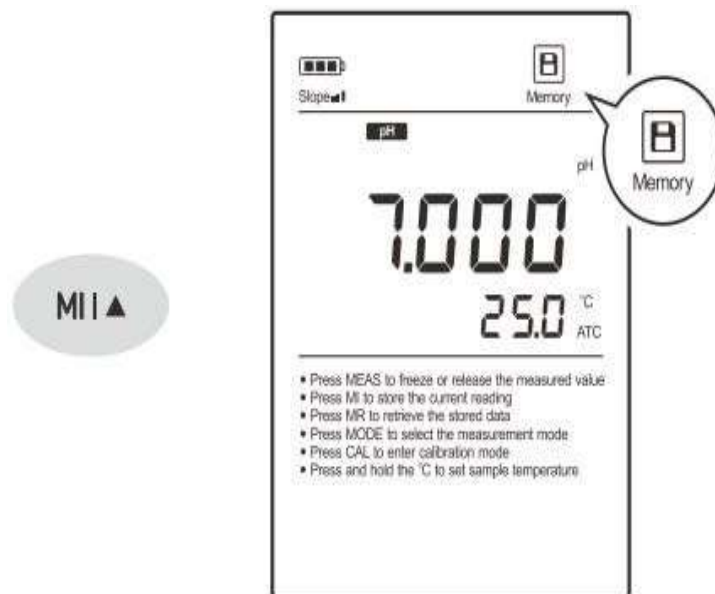
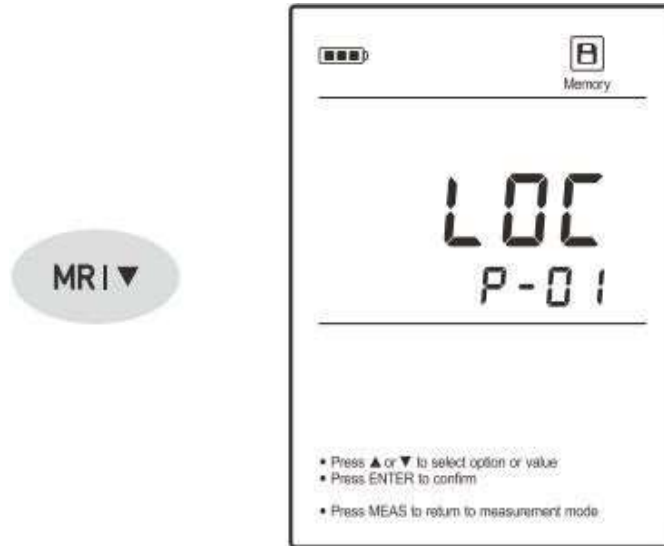

Figure-91

## 7.11.1.2 Viewing the Data Logs

- 1) Press the **MR** key in the measurement mode, the meter shows **LOC/P-01** (Log).



**Figure-92**

- 2) Press the Enter key, the meter shows the serial number of stored data.

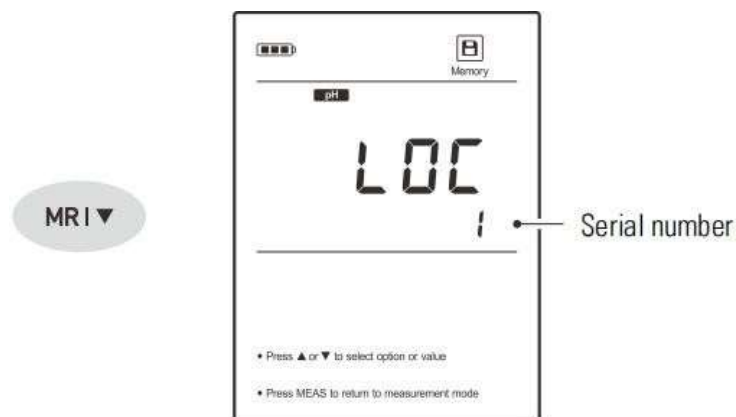

**Figure-92**

- 3) Press the ▼ key to view the date and time of measurement

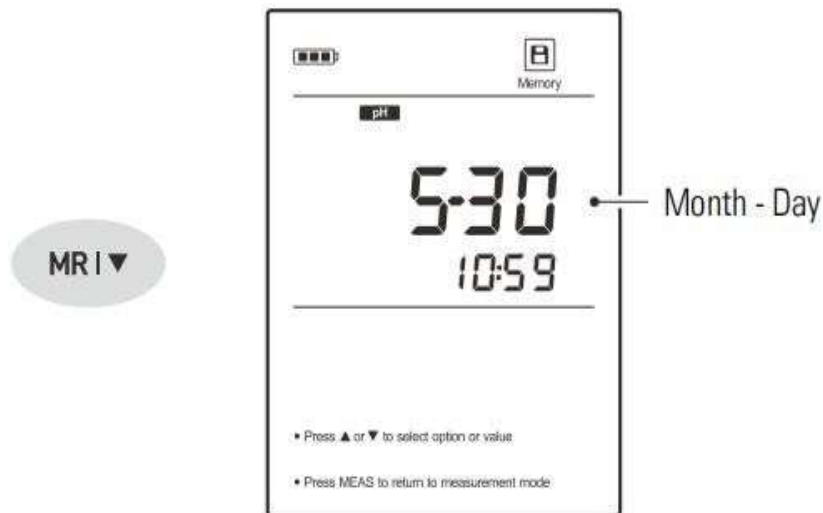

**Figure-93**

4) Press the ▼ key to view the stored data

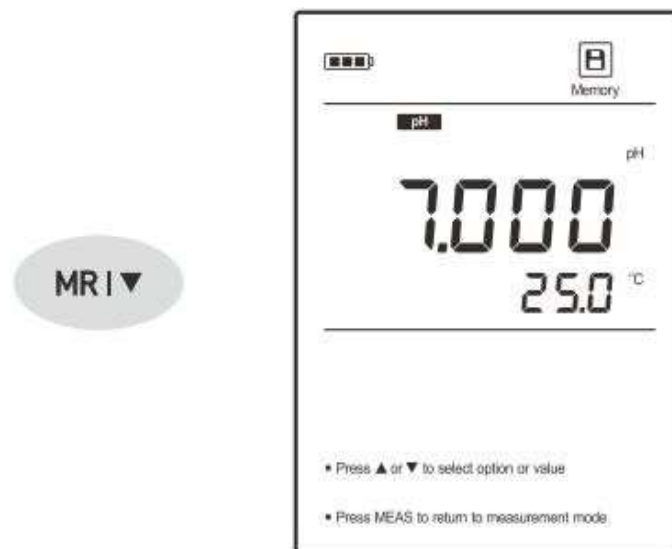

**Figure-94**

5) Press the ▼ key to view the next data set.

6) To exit the data log, press the Meas key.

If the meter does not store any reading, the display will show--only.

### 7.11.1.3 Clearing the Data Logs

If the memory is full, the meter will automatically show **FULL** when the MI key is pressed. To delete the data logs, kindly follow the steps below.

1) Press and hold the  key to enter the setup menu.

2) Press the ▼ key until the meter shows **CLr.**

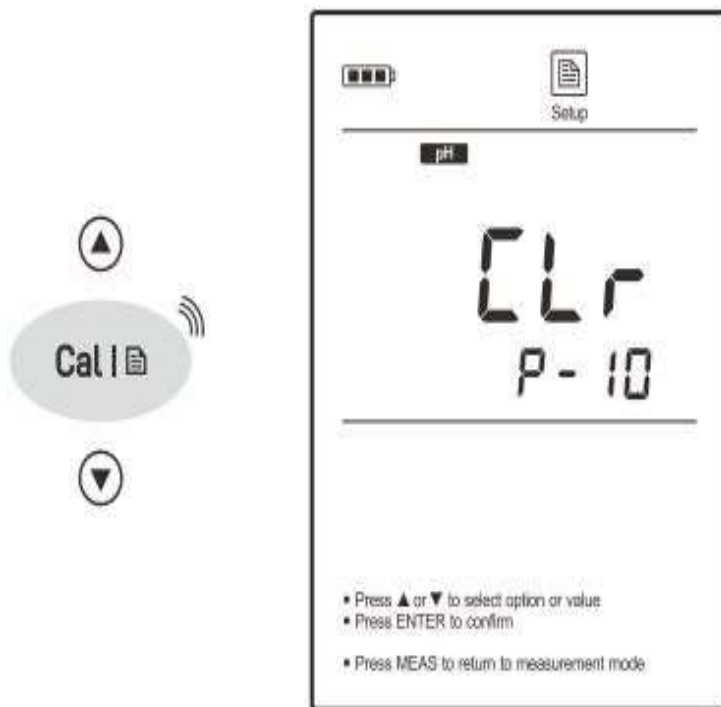

**Figure-95**

- 3) Press the **Enter** key, the meter shows *NO/CLR.*
- 4) Press the **▼** key to select the *YES / CLR .*
- 5) Press the **Enter** key to confirm.

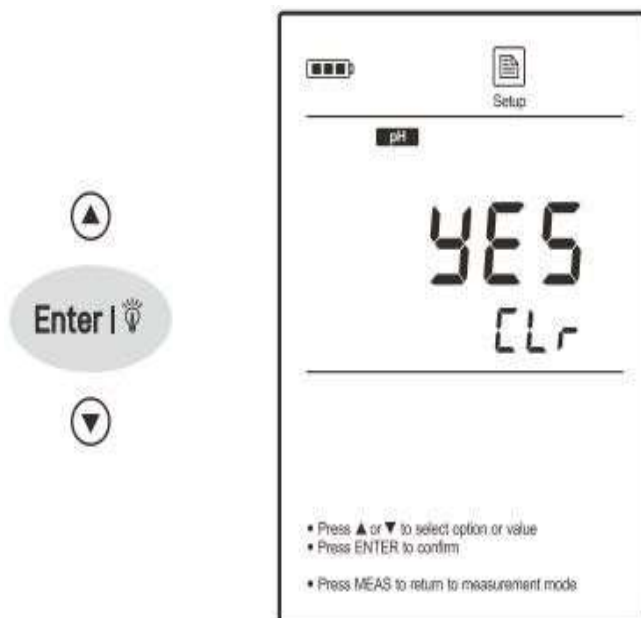

**Figure-96**

## 7.11.2 Communication

The meter can transfer the data to computer or importing the data to Excel by a free DAS software. User can download this software from our official website. Before installation, make sure that the Windows 10 operating system has been installed on your computer.

### 7.11.2.1 Receiving the Data

- 1) Connect the USB cable to meter and click the DAS\_9\_Series icon, the system automatically scans an available communication port and shows a message box "Found a port on your computer".
- 2) Click the **OK**, the application starts.
- 3) Click the **Connect**, the screen shows "Port is connected".
- 4) Click the **OK**, then click the Receive, the stored data will transfer to computer automatically.

### 7.11.2.2 Interval Readings

- 1) Click the **Interval Recording** option box and select a time option.
- 2) Click the **Receive** button to begin record the readings.
- 3) The first data will be shown on the screen after 1 minute.
- 4) Do not press any key on meter during the Interval Readings mode, it will cause communication interruption.

### 7.11.2.3 Creating an Excel File.

- 1) When transfer is completed, click the **Save** as Excel, the readings in data sheet will automatically convert to Excel file.
- 2) **Note**, once the software is closed, all received data will be lost and cannot be recovered.

## 8. Troubleshooting

Fault	Cause and Corrective Action
Screen shows - - - -	Electrode dried out. Soak the pH electrode in 3M KCl solution for about 30 minutes. Soak the ion selective electrode in 100 ppm standard solution for about 30 minutes. Soak the conductivity electrode in tap water for about 10 minutes.
	Measurement exceeded the maximum range. Check the electrode and sample.
Drifting erratic readings	Check whether electrode is contaminated, clogged or broken.
Screen shows Err	pH buffer problem. Use freshly prepared buffer solutions to calibrate the meter.
	Electrode has expired. Replace pH electrode.
	DO electrolyte solution is depleted. Refilling electrolyte solution.
	Zero oxygen solutions are contaminated. Replace the calibration solution.
Keypad is not working	Replace the batteries.

## 9. Accessories

### Standard Accessories

Accessories	Quantity
Plastic pH Electrode	1
Conductivity Electrode	1
Temperature Probe	1
pH Standard Buffer Reagent	1
Conductivity Standard Solution	1
AA Battery	1
Electrode Clip	1
Plastic Carrying Case	1



Labotronics Scientific. 1007 N Orange St., Wilmington, DE 19801, USA.  
info@labotronics.com | www.labotronics.com